

DURHAM GEO  SLOPE INDICATOR

**S-511
Triaxial Cell**

Operator's Manual

Version 3.0

Durham Geo Slope Indicator
2175 West Park Court
Stone Mountain, GA 30087
USA

Phone: 800-837-0864
Fax: 770.465.7447
e-mail: solutions@durhamgeo.com
www.StormwaterSamplers.com

FIRST RECORD THIS INFORMATION

Locate your machine's Model and Serial Number. Should you ever need to call for service, you will need these numbers. You'll find them on a plate on the front or bottom of your equipment.

Model # _____

Serial # _____

Give both of these numbers if you ever need to call for service.

You will also find it convenient to have the following information.

Sold by: _____

Date Purchased: _____

THE OPERATOR SHOULD READ THIS ENTIRE MANUAL CAREFULLY BEFORE ATTEMPTING TO OPERATE THIS EQUIPMENT.

- DANGER** Indicates serious injury or death WILL result if instructions are not followed.
- WARNING** Indicates a strong possibility that serious personal injury or death may result if instructions are not followed.
- CAUTION** Indicates a possibility that minor injury could result if instructions are not followed.
- NOTICE** Indicates that equipment or property damage could result if instructions are not followed.
- NOTE** Gives helpful information.

All information, illustrations and specifications in this manual are based on the latest information available at the time of publication. We reserve the right to make changes at any time without notice and without incurring any obligation.

TABLE OF CONTENTS

CHAPTER 1

Cell Description	3
-------------------------	---

CHAPTER 2

1. General Operating Procedures	4
a. Disassembly of the Cell	4
b. Assembly of the Cell	4
c. Filling and Draining the Cell	
d. Installation of Drainage Tubing	4
e. Base Pedestal Installation	4
2. Procedures for Setting up a Permeability Test	4
a. Sample Set-up	4
b. Pressurizing the Cell	4
c. Saturating the Sample and Drainage Lines	4
3. Measurement of Permeability	4
4. Dismantling the Test	4

CHAPTER 3

Care of the Cell	7
Replacement Parts	4

CHAPTER 4

Limited Warranty	13
-------------------------	----

CHAPTER A

Annex	16
--------------	----

CELL DESCRIPTION

A Triaxial/Permeability Cell is a device in which a cylindrical soil sample can be confined between two porous stones and surrounded by a rubber membrane. The rubber membrane is forced against the sides of the sample by a confining pressure. Drainage lines are provided at both ends of the sample so that permeant can be forced to flow through the sample. The permeability of the soil sample can be determined by measuring the quantity of permeant that flows through the sample versus time.

The Triaxial/Permeability Cell can be used with permeants that are corrosive. The permeant comes in contact only with the cast acrylic or stainless steel end caps and the drainage tubing. Different types of tubing can be selected to be compatible with the permeant that is to be used. If the tubing or cast acrylic deteriorates, it can easily be replaced.

The bottom plate has four drainage lines which exit the bottom of the unit through 1/8" male tube fittings. Each drainage line terminates at a "no volume change" on/off valve.

The bottom plate is also provided with a quick-connect fitting through which the cell is filled and drained. A quick-connect at the top of the top plate is used to vent the cell when it is being filled or drained.

1. GENERAL OPERATING PROCEDURES

A. DISASSEMBLY OF THE CELL

First, vent air pressure through the top quick connect fitting using the male quick connect provided. The cell can be disassembled by first removing the three top clamping knobs, which allows the top plate to be lifted away from the cell. Next, the cell chamber can be removed. Check to insure the bottom and top plate O-rings remain in place as the cell chamber is removed. Be sure to place the cell chamber in a safe, clean area. The acrylic chamber can be easily damaged if dropped or mishandled, soil on the ends of the chamber may prevent a tight seal when reassembling.

During normal operations, the three clamping tie rods should be left in place. If it becomes necessary to remove the rods, hold each tie rod vertically and then remove.

B. ASSEMBLY OF THE CELL

Check to see that the grooves in the top and bottom plate are free from dirt and that the O-rings are seated in their grooves. Wipe off any dirt from the ends of the cell chamber and apply a thin coat of silicone grease. Place the cell chamber onto the bottom plate. Press down slightly on the cell chamber and rotate it a few degrees in each direction in order to seat it against the O-rings and form a seal. Next, place the top plate onto the cell chamber and rotate a few degrees in each direction in order to seat it against the O-rings and form a seal.

CAUTION →

Always assemble the cell with the Band Latches (Fig. 2 Item 6) to the rear and away from the operator!

Next push the tie rods into place and ensure they are straight and in the recess provided in the top cap. Next tighten the tie rod knobs onto the tie rods, tighten the knobs evenly in 1/4 turn increments.

C. FILLING AND DRAINING THE CELL

The cell is filled and drained through the female quick-connect on the bottom plate. A male quick-connect for 1/4" tubing has been provided for this purpose.

The cell must be vented through the female quick-connect in the top plate when being filled or drained. Inserting the male quick-connect into the female quick-connect in the top plate will vent the cell. It is a good idea to have a length of 1/4" tubing connected to the vent quick connect, when filling this will allow water to flow into a receptacle or sink.

CAUTION →

Before attempting to vent the cell, (by inserting the male quick connect) insure that the cell supply pressure is set to Zero or vented.

D. INSTALLATION OF DRAINAGE TUBES

Top Cap- The triaxial or permeameter is supplied with top cap drainage tubing connected to the outside set of black handled valves. (see fig. 2 or fig. 4).

Note: The tubing is not broken at the base. This is to avoid air traps in the tubing. The tubing is one length from the Top cap to the valve. The Base connector is used only as a seal between the chamber and the O.D. of the tubing.

Detail A- shows the most current method of connecting the drain tubes to the top cap. Components consist of 2 ea. 2404006 O-rings and 2 ea. knurled clamping bolts.

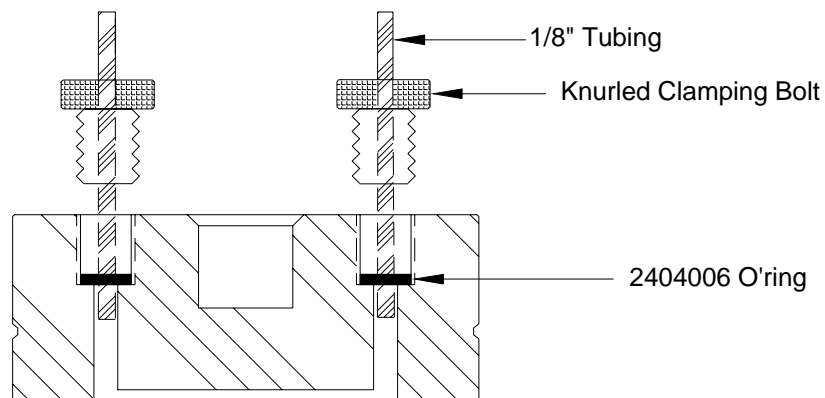

1. Insure the clamping bolts are not tight in their respective threaded holes.
2. Insert 1/8" drainage tube through the center hole of the clamping bolt, and the 006 O-ring. The 1/8" tube should extend approximately 1/8" to 1/4" past the 006 O-ring.

OPERATION

3. Tighten the Clamping bolt BY HAND only, this will be sufficient to seal the tubing.

Detail B- shows one method of connecting tubing into acrylic top cap.

Note: (This type of top cap connection is no longer shipped with cells.)

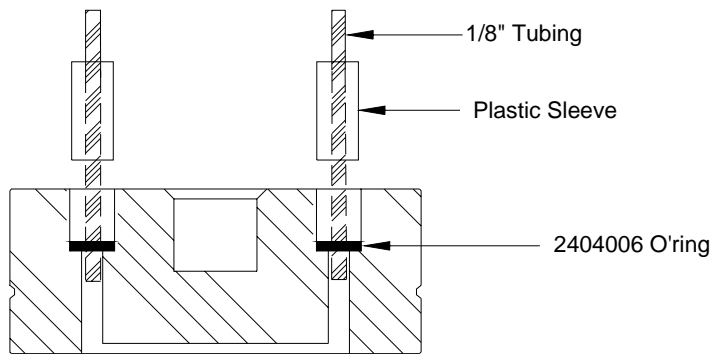

1. Install plastic sleeve over tubing first.
2. Check that O-ring is in place at bottom of drilled hole. Use small amount of silicone grease around 1/8" tubing, being careful not to get silicone grease on the ID of the tubing.
3. Place tubing through connector until flush with underside of top cap drainage groove.
4. Push plastic sleeve down onto O-ring.
5. Repeat for other top drainage line.

Detail C- Shows another method of connecting 1/8" tubing to the top cap using a Swagelok® stainless steel fitting.

Note: (This type of top cap connection is no longer shipped with cells.)

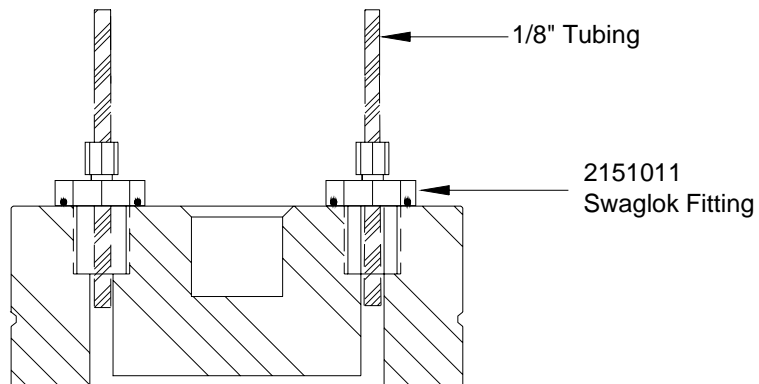

1. Remove Swagelok® nut, front ferrule and back ferrule from fitting.
2. Insert the tubing through the nut, Back ferrule and Front ferrule.
4. Place the tubing through the connector until flush with underside of top cap drainage groove.
5. Tighten nut down finger-tight, then use a 7/16" wrench and turn 1/2" turn more to seal the tubing.

Note: Over tightening will cause ferrule to crush the tubing and possibly reduce the flow.

E. BASE PEDESTAL INSTALLATION

The base pedestal and drainage tubing are supplied, factory installed and tested.

1. To remove pedestal use an allen wrench to unscrew (counter-clockwise) retaining Bolt on the bottom center of the cell base .
2. Lift pedestal away from base carefully.

Note: The dowel pin is required to stop rotation of pedestal when tightening the retaining bolt.

2. PROCEDURES FOR SETTING UP A PERMEABILITY TEST

Note: Outlined below are general procedures for setting up a permeability test and is a guideline only. Other procedures work just as well and should be adopted if the user feels that they are more operative to their test requirements.

A. SAMPLE SET-UP

1. Disassemble the cell and check all O-ring (See Page 4). Select the top cap and the base pedestal that are to be used. Install the base pedestal and it's drainage tubes. *The top drain tubing should not be connected to the top cap at this point.*
2. Apply a thin coat of silicone grease to the sides of the base pedestal and top cap.
3. Prepare a soil test specimen by either trimming from an intact sample or remolding in a mold to the desired density and moisture content.

4. Place the following items on the base pedestal in the following order: 1 porous stone, 1 sheet of filter paper, soil test specimen, 1 sheet of filter paper, 1 porous stone, and the top cap. Saturate the porous stones before placing them on the base pedestal. The filter paper is used to prevent fine particles from clogging the porous stones. When placing the top cap, position it so that the clamping bolts are aligned with the drainage tubes.

Note: You may wish to moisten two 1/2" wide strips of filter paper that are long enough to wrap around the sample. This filter paper prevents the membrane from being cut on the edges of the pedestal, top cap, or porous stones.

Notice: If the permeant that is to be used will attack a latex membrane, or is chemically not compatible with latex, the user should consider another type of membrane (Nitril for instance) that is compatible with the chemistry of their permeant. User should seek assistance from a competent professional before selecting the membrane material.

5. Two methods are generally used for membrane placement. The selection of this method depends on the consistency of the test specimen and which tools are available to the user.

- a. The first procedure can be used if the sample is relatively stiff:

Cut the membrane to length, approximately 2" longer than the cumulative heights of the test specimen, Porous stones, top cap and base pedestal. Roll the membrane down and stretch it onto the pedestal so that it can be unrolled upward. This should be done before the test specimen is put into place. After the test specimen, porous stones, filter paper, top cap, have been positioned, unroll the membrane upward around the sample. A slight downward pressure on the top cap may be needed to prevent the sample from deforming. Be sure that the membrane extends equidistant on each end so that the supplied O-rings can be put into place on the cap and pedestal. Place an O-ring over the membrane and into the groove on the cap and Pedestal.

- b. The second method requires the use of a membrane stretcher. A membrane stretcher is a thin walled tube that has an ID that is slightly bigger than the O.D. of the sample. The length of the tube should be approximately 1" longer than the length of the sample. The stretcher has a vacuum port at approximately mid-length. Put two O-rings (for the size sample to be used), onto the O.D. of the stretcher, one on each end. Place the membrane inside the stretcher and fold the ends of membrane over the edge of the stretcher. Assemble the top cap, stones, filter paper and Pedestal. Using the tube supplied, place a vacuum on the port so that the membrane is pulled to the inside wall of the stretcher. Maintain a vacuum and slip the stretcher over the prepared sample. When the membrane is aligned properly, release the vacuum, allowing the membrane to confine the sample. Pushing down slightly on the stretcher, roll one O-ring off of the top of the stretcher onto the cap. Lift the stretcher

slightly and roll the second O-ring off of the bottom of the stretcher onto the pedestal. Lift the stretcher from the sample carefully and insure the O-rings are in the correct position.

6. The final step before assembling the cell is to connect the top drain tubs to the clamping bolts on the top cap. When tightening be sure to hold the top cap in place so that it does not rotate and disturb the sample.

B. PRESSURIZING THE CELL

1. Assemble the cell and fill it as described previously. When filling the cell with water, fill it at a rate so that air bubbles are not trapped. Try to remove as many bubbles as possible when filling the cell. Be sure to fill the cell completely by allowing water to flow out the top quick-connect. Pressurize the cell through bottom quick-connect. The pressure applied to the cell should be 2 to 5 psi greater than the pressure that is to be used back pressure saturate or to force the permeant through the sample, otherwise the membrane will balloon away from the sample.
2. After pressurizing the cell, check for leaks. Any large leaks around the cell wall usually indicate that an O-ring was not seated properly. In this case, depressurize the cell, drain it, disassemble it, and seat the O-ring. Small leaks around the cell wall can usually be stopped by additional tightening of the knurled nuts.
3. If water is flowing out of any of the drainage tubes, there is either a hole in the membrane, a loose top drain fitting, a leaky O-ring under the base pedestal, or a hole in the top drain tubing. To fix any of the above problems requires that the cell be disassembled. A leaky membrane can be fixed by placing a second membrane and O-rings over the first.
4. Any leakage around the tube connectors on the bottom of the base indicates that either the fitting is loose or the nut is loose. Tightening both should stop the leak.

C. SATURATING THE SAMPLE AND DRAINAGE LINES

After pressurizing the cell and making certain that there are no leaks, the next step is to saturate the drainage lines and the sample.

1. First, saturate the drainage lines that lead to the base of the sample by allowing water to flow into one drain and out the other. Best results can be achieved by using de-aired water and occasionally stopping and restarting the flow so that any bubbles which adhere to the sides of the drainage lines can be loosened. Be sure that the pressure used to force the water through the base drain is less than the cell pressure. Close all valves once the lines have been filled.
2. The same procedure is used to saturate the top drains lines. Close all valves once the lines have been filled.

3. Saturation of the sample should be completed according to the project specifications. ASTM, and ASHTO have standards that apply to saturation and triaxial testing.

3. MEASUREMENT OF PERMEABILITY

After saturating the sample and drainage lines, the permeability of the sample can be determined by measuring the amount of permeant that flows through the sample versus time. The user is referred to one of the numerous texts on soil testing for information concerning the procedures for performing the test.

4. DISMANTLING THE TEST

After testing is complete, relieve any pressure inside the sample. If a corrosive or toxic permeant was used, flush the top drains and base drains with water to remove the permeant. If the sample is to be handled or used for additional testing, it may be wise to flush the sample with water also.

Once the sample pressure has been relieved, depressurize the cell, drain it, and then remove the top plate and cell chamber. Disconnect the top drain tubing from the top cap. The O-rings and membrane can be removed while the base pedestal is attached to the base plate. However, in order to keep the groove for the cell chamber free of soil or from spilling permeant, it is possible to remove the pedestal from the cell base. The membrane can then be removed in a sink or another appropriate area. After the sample is dismantled, rinse the top cap, base pedestal, and drainage tubes.

CARE OF THE CELL

The cell is designed so that, if a corrosive permeant is used, it will only come in contact with the drainage tubes, top cap, and base pedestal. If any corrosive permeant accidentally spills on any other parts of the cell, rinse it immediately.

Check the cell chamber before each use for any signs of cracking or crazing. If either are detected, replace the cell chamber immediately.

When installing new tube connectors in the top cap, be sure not to over tighten them.

Replacement Parts

Occasionally the O-rings may need replacement. The following O-rings are used and can be obtained from a local supplier:

Part Number	Qty	Description
Replaceable Seals:		
152504	1	Huva seal
O-rings:		
2404157	2	In the groove for the cell chamber in the top and bottom plate.
2404012	1	On the bottom plate around the bolt for the base pedestal.
2404006	2	In the bottom plate around the base pedestal drain holes.
2404006	2	Top Cap beneath the clamping bolts.
2404007		Male quick connect replacement O-ring.
Apply a thin coat of silicone grease to all replacement O-rings before they are installed.		
Parts:		
167401		Triaxial chamber
2151097		Female quick connect
116701		SS Chamber band
4800-3-2		Band Latch for chamber band
G-52508		1/8 Nylon tubing
G-52608		1/8 Teflon tubing
S-51005		Male quick connect to 1/8" tubing. Pack of 2.
Accessories:		
S-51003		Top and tube assembly (perm to Triax conversion kit). Includes acrylic chamber, top with loading shaft, 3 triaxial tie rods.
S-51001		Triaxial top only (with loading shaft and bearings).
E-124		Pore pressure transducer (0-150 psi).
E-405		Digital readout.
S-500		Permeability panel (master panel 3 burettes)
S-502		Permeability panel (add-on panel with 6 burettes), S-500 required to use.
E-310		1/2" Linear displacement transducer. (E-400 and E-344 required).
E-344		Adapter for E-310.
To use the following owing substitute the size required for X (Example: S-52014 = 1.4 Acrylic cap and pedestal.		
S-520XX		Acrylic cap and pedestal with O-rings.

OPERATION

S-521XX		Stainless Steel cap and pedestal with O-rings
S-550XX		Porous Stones
S-540XX		.012 Thick latex membranes (qty of 12)
S-541XX		.025 Thick latex membranes (qty of 12)

LIMITED WARRANTY

Durham Geo Slope Indicator. warrants the TRIAXIAL/PERMEABILITY CELL to be free from defects in material and workmanship under the product's normal, intended and proper use for a period of ONE (1) year from the date of shipment. Durham Geo-Enterprises' obligation under this warranty shall be limited to replacing or repairing the defective part or parts, solely at our option. Any defective part or parts must be returned, freight prepaid by buyer, to Durham Geo-Enterprises' plant for inspection.

This limited warranty does not apply to defects in performance caused by: (1) use of the product in an environment that is hostile to the products material such as, but not limited to, abrasive materials, corrosive chemicals, lightning, improper voltage supply, improper or lack of routine maintenance, mishandling or misapplication; (2) repairs and replacements due to normal wear; (3) use of the product in applications other than its designed and intended use: and (4) repairs or attempted repairs to the product performed by persons other than Durham Geo-Enterprises' authorized plant repair personnel. Any such attempted repairs shall void any and all warranties.

Durham Geo-Enterprises is constantly striving to improve its products and therefore reserves the right to change materials, design, specifications, and price without notice.

For a complete warranty disclosure, please contact us

e-mail info@durhamgeo.com

Call 1-800-837-0864 (outside Georgia, USA) or
(770) 465-7557 (inside Georgia, USA)

Refer to the printed statement on the back of any Durham Geo Slope Indicator original invoice.

ANNEX

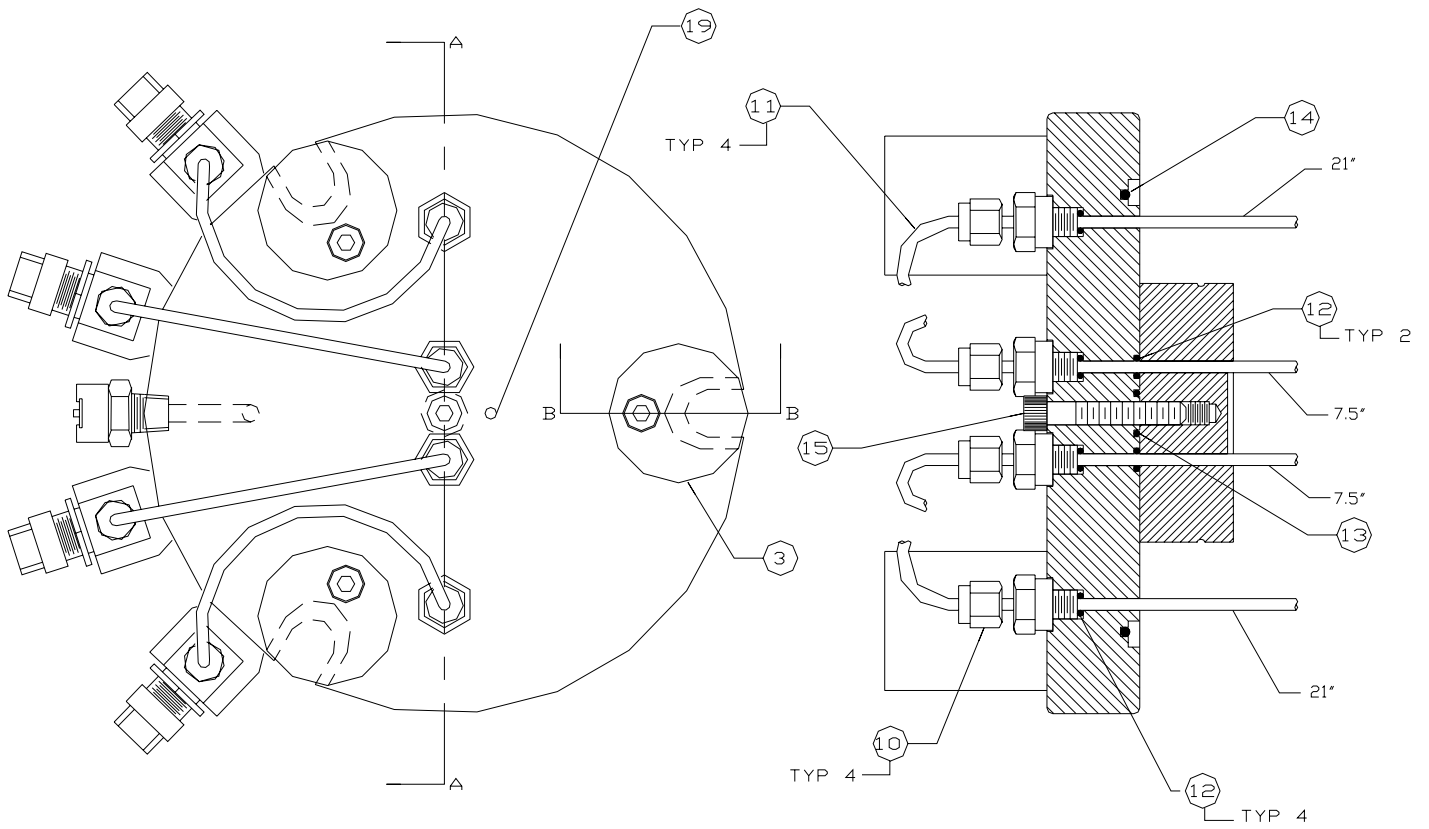

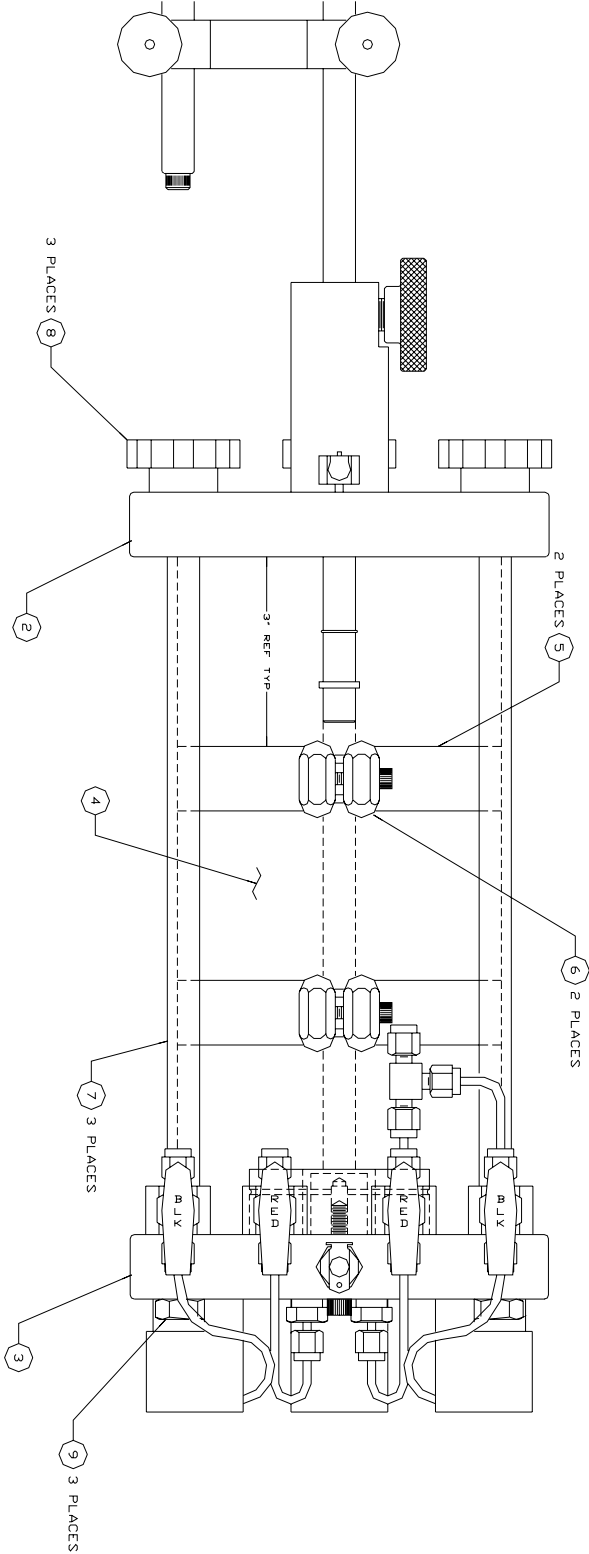

ANNEX

ITEM	QTY	QTY	QTY	QTY	PART NUMBER	DESCRIPTION	SUPPLIER / MANUFACTURER
①	X				S-511	TRIAxIAL CELL ASSEMBLY, S-511	
②	1				DETAIL	TOP PLATE ASS'Y, TRIAXIAL CELL S-511	
③	1				DETAIL	BASE PLATE ASS'Y, TRIAXIAL CELL S-511	
④	1				186101	ACRYLIC CHAMBER	
⑤	2				116702	SS FORMED BAND	
⑥	2	2			480032	BAND LATCH ASS'Y	4800-3-2
⑦	3	3			154303	TIE ROD	
⑧	3	3			230801	KNOB, TIE ROD	
⑨	3	3			- - - -	HEX NUT, 1/2-20 UNF	
⑩	1	-			2712-01	TRIAxIAL CELL KIT, 1.4"/2.8" (NOT SHOWN)	
⑪	-						
⑫	-						
QUANTITY FOR PART NO. S-511					Durham Geo  SLOPE INDICATOR		
PROJECT					TITLE		
TRIAxIAL CELL					TRIAxIAL CELL ASSEMBLY, S510/S510A		
REVISION	A	B	C				
DATE	8/26/91	01/21/92	10/30/96				
DATE	08/26/91				DRAWING NO.	2713	

ANNEX

ANNEX

ANNEX

ANNEX

ANNEX

A N N E X