

**Direct Shear Machine**  
**LG-116**

**Operator's**  
**Manual**

Version 1.0

**Durham Geo Slope Indicator**  
2175 West Park Court  
Stone Mountain, GA 30087  
USA

Phone: 800-837-0864 or  
+1.770.465.7557  
Fax: 770.465.7447  
e-mail: [solutions@durhamgeo.com](mailto:solutions@durhamgeo.com)  
[www.DurhamGeo.com](http://www.DurhamGeo.com)

# TABLE OF CONTENTS

CHAPTER 1		CHAPTER 3	
<b>Introduction</b>	3	<b>Maintenance</b>	15
Setting Up	4		
CHAPTER 2		CHAPTER 4	
<b>Running a Test</b>	6	<b>Troubleshooting</b>	16
Using the Digital Readouts	7		
Applying Normal Loads	10	CHAPTER 5	
Preparing the Sample	10	<b>Specifications</b>	19
Attaching the Membrane	11		
Preparing the Soil	12	CHAPTER 6	
Adjusting the Shear Box	12	<b>Limited Warranty</b>	21
Adjusting travel	13		
Checking Limit Switches	13	CHAPTER 7	
Measuring Normal Load	14	<b>Parts Lists and Drawings</b>	22

RECORD THE FOLLOWING INFORMATION FOR FUTURE REFERENCE	
<b>Type / Model</b>	
<b>Unit Serial Number</b>	
<b>Date Purchased</b>	
<b>Vendor (Purchased From)</b>	<input type="checkbox"/> <b>Direct from Durham Geo Slope Indicator</b> <input type="checkbox"/> <b>From Distributor (Name) _____</b>
<b>Other</b>	

# INTRODUCTION

## 1. Introduction

### **CAUTION!**

Read the complete manual prior to operating this piece of equipment. Improper operation can result in damage to the equipment or operator. If you have any questions concerning the safety, operation, or applicability of this equipment, please contact Durham Geo Slope Indicator.

Thank you for purchasing a Durham Geo Slope Indicator Direct Shear Machine. This machine has been designed to perform the necessary tests to measure friction between a geotechnical liner and soil. This machine will accommodate samples up to 12 inches x 12 inches (305 mm x 305 mm) square. We can also provide a standard insert for testing 6 inch x 6 inch (152 mm x 152 mm) samples. If you need other sizes, please contact the factory.

This LG-116 has been assembled and packaged to strict quality standards. However, occasionally circumstances beyond our control may result in damage during shipment. Please inspect all packages on receipt and note any missing or damaged parts. If you find any problems, please contact your Durham Geo Slope Indicator representative or call our Stone Mountain office.

This manual addresses the installation, setup, and operation of the following Durham Geo Slope Indicator Models:

- LG-11225 - Shear Box
- LG-117 - Drive Unit
- LG-11220 - Rigid Load Platen (for application of low (< 1000 lbf) normal loads)

Unless otherwise noted, all references to LG-117 also apply to the LG-11720. For information on the setup and operation of the transducers and readouts that accompany this unit, please refer to the manuals.

All information, illustrations, and specifications included in this manual are current as of date of publication. Durham Geo Slope Indicator reserves the right to make changes at any time without notice. As believers in the continuous improvement

process, we encourage our customers to comment on our goods and services and work with us in developing solutions to problems.

## 2. Components

The LG-116 consists of the following subassemblies:

- LG-11225 Shear Box Unit (Figure 1)
- LG-117 Drive Unit (Figure 2)
- 432701 - Transducer Assembly with 4-inch Linear Displacement Transducer (Figure 3)


## 3. Unpacking

Before unpacking your unit, examine the packaging for signs of external damage. Make a note of any damage you find. If the damage appears to be extensive, please contact Durham Geo Slope Indicator Customer Service .

As you unpack your unit, check to be sure that the items on the packing list correspond to the items that you receive. Note any discrepancies and contact Durham Geo Slope Indicator as soon as possible.

## 4. Setting Up

After unpacking the unit, place the drive unit and the Shear Box unit on a sturdy, level surface with access to 100 psi (690 kPa) air service and the appropriate AC supply voltage. Position the unit so that these connections and the corresponding hoses and cords are not in the normal working area.

	<p><b>NOTICE:</b> Due to the weight of a full soil box, it is important to leave clear access to both sides of the Shear Box for safe handling.</p>
---	---

Prior to running a test, familiarize yourself with making the connection between the Shear Box and the drive unit. This process is fairly simple, but you may find it beneficial to run through the process with an empty soil box the first time.

### 1.0 Instructions

---

- 1.1 Position the Shear Box (Figure 1) so the operator can access the front of the unit easily. The Shear Box must be level in both the horizontal and vertical axes. If the box is not level, use the adjustable feet (Figure 1, item 9).
- 1.2 Place the positioning handle (Figure 2, item 1) on the drive unit carriage.

- 1.3 Roll the drive unit up to the Shear Box. The height of both machines is preset at the factory. Visually check that the alignment pins are at the same height.
  
- 1.4 Carefully push the drive unit onto the alignment pins in the side of the Shear Box. At the same time, ensure that the drive unit tie rods are lined up with their mating points on the Shear Box. If the box and drive unit doesn't go together smoothly, check that the surface is level. If you determine that this is not the problem, or if you cannot find a level surface, the height of the Shear Box may be adjusted. Refer to the troubleshooting section for instructions on adjusting the height of the Shear Box.
  
- 1.5 Place the clamp loop (Figure 1, Item 1) on the Shear Box over the receiver (Figure 2, Item 3) on the drive unit. Flip the toggle clamp back to secure the Shear Box to the drive unit. Actuating the clamps should pull the drive unit tight to the Shear Box. Visually inspect the unit to ensure that there is no gap when the clamps are locked. To ensure accurate results during testing, there should be no gap between the units when the clamps are locked. Refer to the troubleshooting section for instructions on removing a gap between the boxes.
  
- 1.6 Screw the coupling nuts (Figure 4, Item 1) on the drive unit tie rods onto the threaded end of the Shear Box tie rods. If the nuts won't reach the Shear Box tie rods, pull the Shear Box closer. If the rods appear to be set at different lengths, refer to the troubleshooting section in this manual for further instruction.
  
- 1.7 Install the Transducer Assembly (Figure 3) on the Shear Box. Place the stainless steel LDT housing over the studs protruding from the right rear (facing the assembled unit) of the Shear Box and tighten it in place with the supplied wing nuts (Figure 5, Item 1).



**Take care that you do not force the LDT in place. There is a travel bracket that the tip of the LDT contacts to measure Shear Box displacement. Do not force the LDT around the travel bracket when mounting the LDT.**

Check to be sure that the LDT is picking up on the travel bracket mounted to the lower plate of the Shear Box. If the LDT is not picking up on the travel bracket, refer to the troubleshooting section for adjustment instructions.

- 1.8 Connect the LDT cable to the drive unit (Channel 3).
  
- 1.9 Connect the data cable and the power cable from the drive unit to the back of the controller.
  
- 1.10 Check to ensure that the load cell (Figure 4, Item 2) cable is plugged into Channel 1. The cables are tagged with the channel number and the sockets are labeled.
  
- 1.11 Plug the main power cord into the drive unit (Figure 5, Item 3).
  
- 1.12 Plug the main power cord into a grounded wall outlet. If a grounded outlet is not available, wire the machine in accordance with your local electrical code.

R U N N I N G   A   T E S T

- 1.13** The unit should now be ready for testing. If you experience any problems with the setup or have any questions about this procedure, please contact your local Durham Geo Slope Indicator representative or call our Stone Mountain office.

## RUNNING A TEST

Running a test on the LG-117 is a fairly simple procedure once the unit has been setup for testing. The instructions and comments in this section assume that you have been able to successfully complete the setup procedures outlined above. This section also assumes that you have prepared the sample and that the sample box has been installed in the Shear Box unit. For instructions on preparing a sample, refer to the "Sample Preparation" section of the manual.

**NOTICE: Please read the instruction manual and familiarize yourself with setting up the machine prior to running a test.**

### 1.0 To run a test:

---

- 1.1 Depress the on/off switch on the front panel of the drive unit to apply power to the unit. The motor will run for a couple of seconds. This is normal and allows the unit to reset itself internally. After the initial startup procedure is completed, the controller will display:  
**ACTUAL POSITION: X.XXX INCHES**  
**PRESS A FUNCTION KEY FOR SELECTION**
- 1.2 Check the transducer connections and ensure that they are in the proper sockets. The correct sockets are shown in the calibration sheets which came with the machine.
- 1.3 Visually check the position of the hand wheel (Figure 2, Item 4) on the drive unit. It should be positioned between the limit switches. The distance from the hand wheel to the front limit switch is the amount of travel available for testing. If there is not enough travel for your test, you will need to adjust the sample box position. Please refer to the "Adjusting the Shear Box" section of this manual.
- 1.4 Tare and/or clear the Digital Readouts as necessary. Please refer to "Using the Digital Readouts" section of this manual.
- 1.5 Set the "Zero" (F3) position on the controller.
- 1.6 Enter the "Move" (F1) mode by depressing the (F1) key.
- 1.7 Using the keypad, enter the distance to travel (in inches).
- 1.8 Enter the velocity desired for the test (in inches/minute). Note: This value must be between .0001 and .2000. (Note: 1 mm = 0.039 inch)

- 1.9 Review your selections. If you are satisfied, depress the "Start" (F5) function. If you want to make a change, depress the "Stop" (F6) function and begin at step 6.
- 1.10 To stop the test after it has begun, depress the "Stop" (F6) function. This will terminate the test and return you to the main menu.
- 1.11 When the move has been completed, the controller returns to the main menu screen.

At this point, you can utilize the "Home" (F2) function to return the Shear Box to the .0000 in (Home) position.

## 2.0 Using the Digital Readouts

---

The readouts, load cell, and LDT supplied with your unit are designed to operate as integrated units. This section gives a brief overview of these devices; it is not intended to be a detailed instruction manual. For problems not covered here, please refer to the appropriate manual for these devices. If you have any questions, please call your Durham Geo Slope Indicator representative.

There are four single-channel readouts supplied with your LG-117 Drive Unit. These readouts process the signal from the instrumentation attached to your box and provide a serial (RS-232) signal which can be processed by a personal computer (IBM or compatible). In order to process the signal from the readout, it is necessary to install the optional "WinSAS" (Serial Acquisition Software) program.

For instructions on installing the optional software, please refer to the WinSAS manual. The readouts and transducers that were shipped with your unit are calibrated at the factory. Refer to the specification sheets for the correct channel.

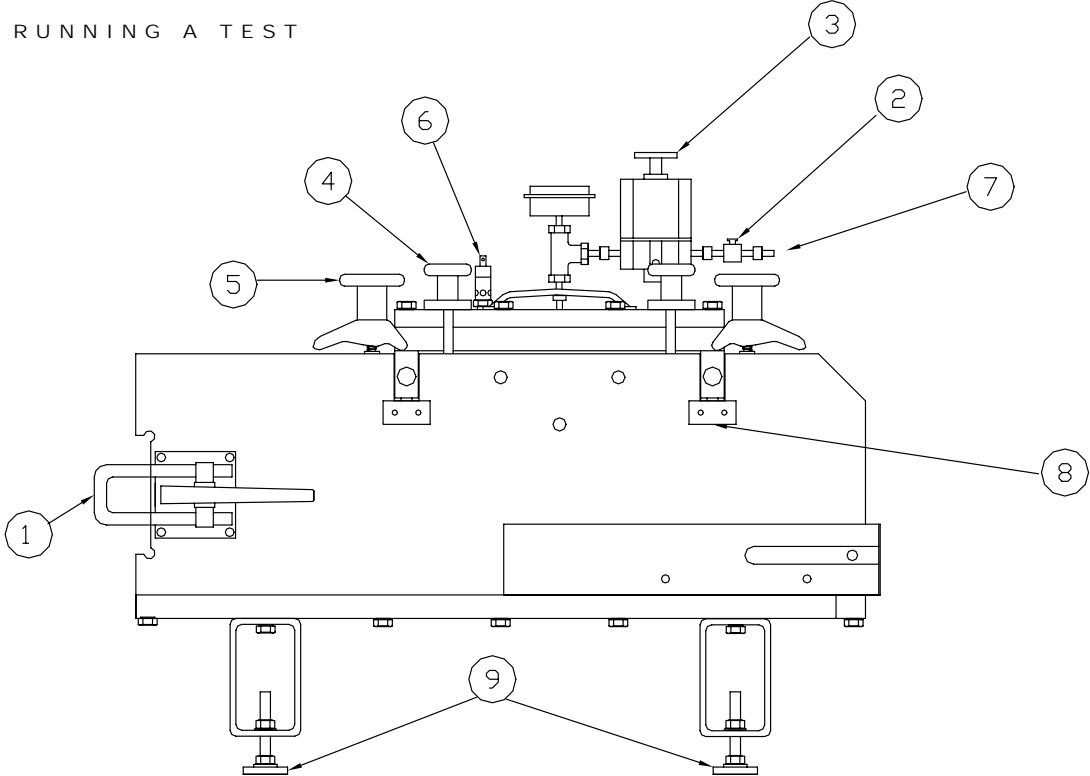
The readouts have a built-in tare and clear function which is actuated by the marked toggle switches on the front panel of the Shear Box drive unit. This feature allows you to set a zero load or zero displacement at any time. To set the zero point, simply toggle the switch to the "Tare" position and hold until the indicator displays "TARE". To clear a tare, toggle the switch to the "Clear" position and hold until the readout says "CLR".



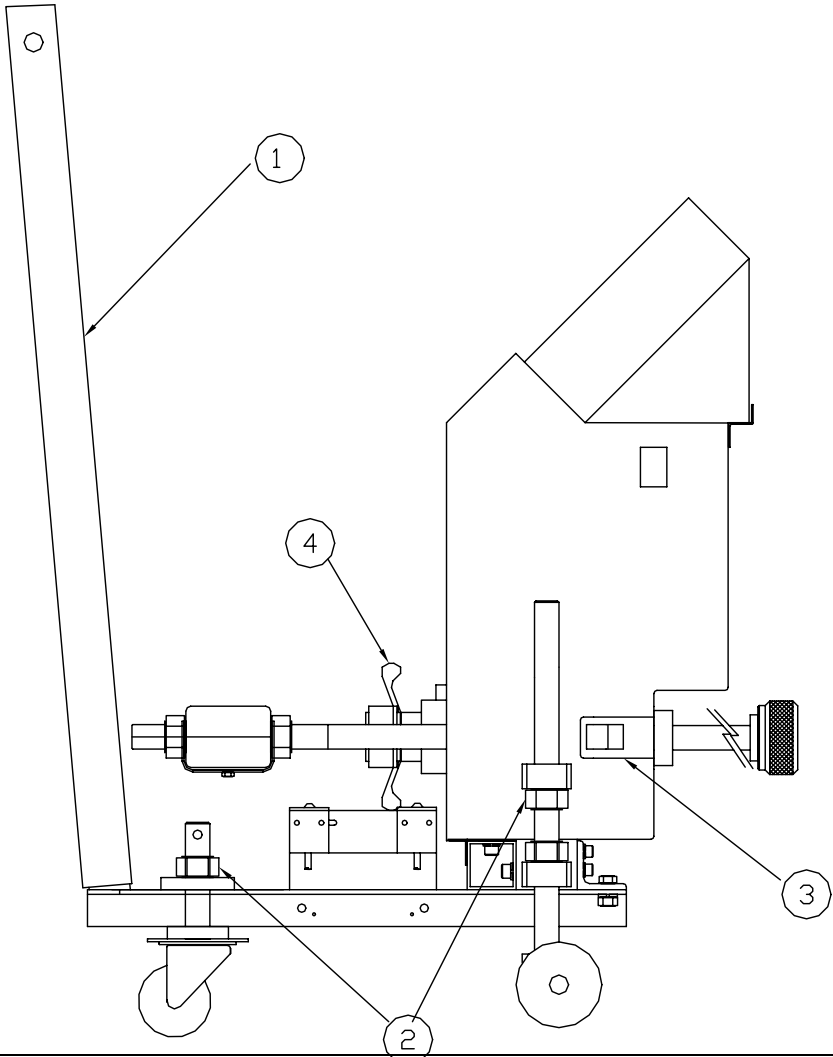
**A large value in the Tare for the load cell may indicate that the cross bar needs adjustment. The load cell should not have more than 5 - 10 lb (22 - 44 N) of load on it when the Shear Box is idle with no sample installed. If there is a large offset and the unit is not in shear, you will need to adjust the cross bar to remove the load.**

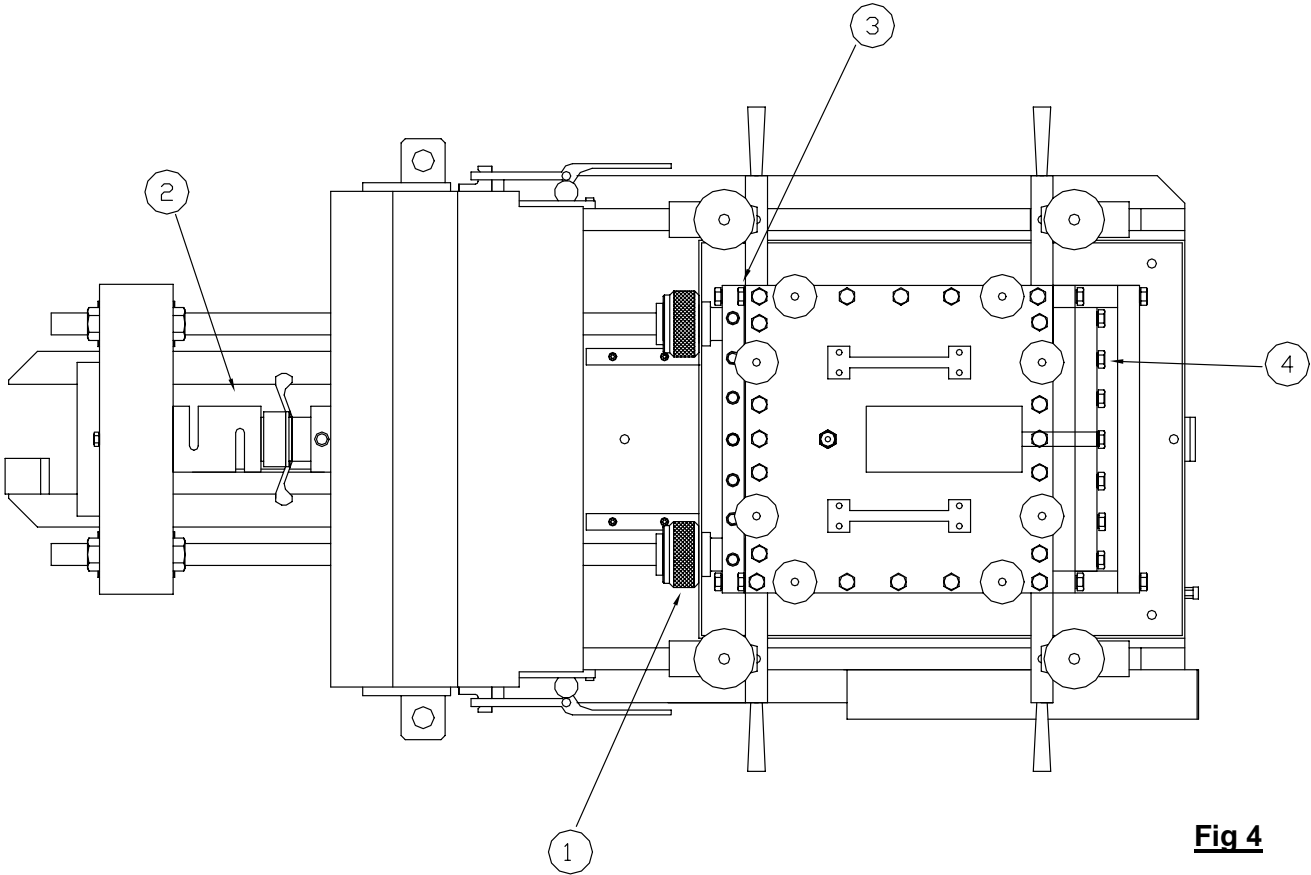
RUNNING A TEST

**Fig 1**

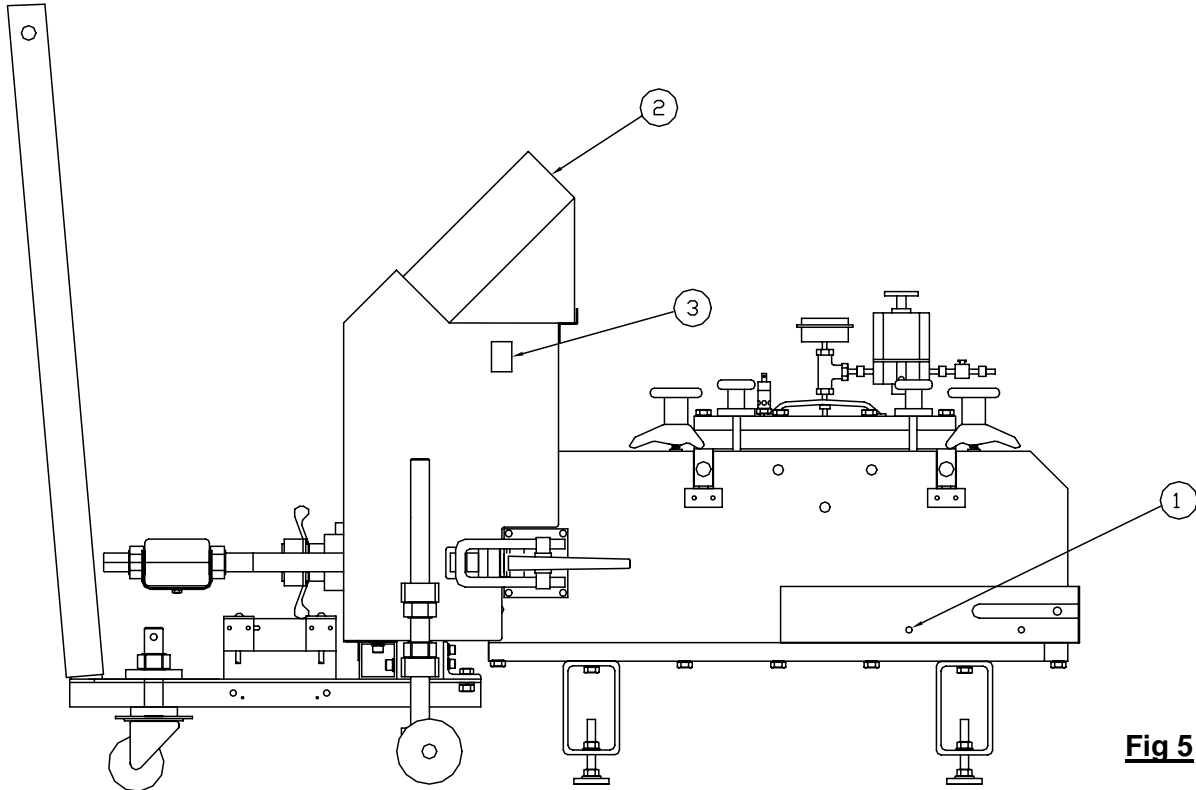


**Fig 2**





**Fig 4**



**Fig 5**

### 3.0 Applying Normal Loads

---

The sample box has an air bladder built into the top of the unit as a standard feature. This unit is designed to operate at a maximum of 100 psi (690 kPa) of dry air. The pressure applied to the bladder is controlled by a ball valve (Figure 1, Item 2) and precision regulator (Figure 1, Item 3) which are permanently mounted to the sample box.

Prior to applying any air to the sample box, check to ensure that the top is secure on the sample box. **At full pressure, there is 14,400 lbf (62 kN) of load on the sample box. All clamps (Figure 1, Item 4) and hold downs (Figure 1, Item 5) must be in place and secure.**

**WARNING !**

**Do not attempt to adjust the regulator above 100 psi (690 kPa). The sample box top has a built-in pressure relief valve (Figure 1, Item 6) that vents at 105 psi (723 kPa). Removal or adjustment to the pressure relief voids all warranties and may cause serious injury to operators or extensive damage to the equipment.**

Normal loads are applied to the sample in the following way:

**WARNING !**

**Prior to applying pressure to the sample box, check that all hold down bolts and clamp knobs are installed and secure. Failure to do so can result in damage to the equipment or injury to the operator.**

**WARNING !**

**Never apply pressure to the bladder without a sample or sample facsimile in the sample box. Failure to comply with this requirement will result in explosive failure of the bladder and may result in damage to the equipment or injury to the operator.**

- 3.1 Attach a ¼ inch air line to the fitting (Figure 1, item 7) going into the brass valve attached to the regulator. Caution: Make sure that the valve is in the "Off position (handle perpendicular to the valve body) prior to connecting the air supply.
- 3.2 With the air line installed, slowly turn the valve to the "On" position
- 3.3 Adjust the regulator to the appropriate pressure for the desired load. For further information regarding this adjustment, refer to the "Adjusting the Shear Box" section of the manual.

### 4.0 Preparing the Sample

---

This section describes the appropriate method for removing the sample box, attaching the geosynthetic to the box for testing, and placing the sample box in the Shear Box unit. This

section does not address soil preparation, compaction, selection of membrane, or other non-machine specific issues. It is up to each user to determine the appropriate testing methodology for their customers and situation. If there are questions concerning test specific areas, please contact the Durham Geo Slope Indicator technical support staff.

To prepare the sample box for receiving the sample:



**Before removing the upper box, use a thickness gauge or sample of the material to be tested to adjust the clearance between the upper and lower boxes. Use the sample box adjusting bolts (Figure 1, Item 8) to set this height.**

- 4.1 Remove the sample box from the Shear Box unit by loosening the 4 hold-down clamps (Figure 1, item 5) and pivoting them out of the way.
- 4.2 Take care when removing the sample box as it is quite heavy. Place the sample box on a level surface for sample preparation.
- 4.3 Loosen the hand knobs on the top of the sample box. Completely remove the knobs on the fixed studs.
- 4.4 Lift the top off using the handles mounted on the unit. Do not lift the top by grabbing the gauge, regulator, pressure relief, or other feature on the top.

The sample box is now ready for sample preparation.

## 5.0 Attaching the Membrane

---

The geosynthetic membrane may be attached to the top sample box, the bottom sample box, or both. Included with the Shear Box unit is a stainless steel template supplied to facilitate cutting out the membrane to fit in the geotextile clamp. To attach a membrane to the lower box clamp:

- 5.1 1. Cut your membrane to size. The maximum recommended width is 12 inches (305 mm). It is also recommended that the length of the membrane be approximately 22 inches (560 mm) to accommodate attaching to the lower box clamp.
- 5.2 Using the cut out template, cut the membrane to fit the clamps.
- 5.3 Loosen the nuts (upper box clamp; Figure 4, item 4) or the bolt (lower box clamp; Figure 4, item 3) enough to provide the appropriate gap for the membrane.
- 5.4 Place the membrane through the lower box clamp plate and tighten the clamp.
- 5.5 If you are clamping to the upper box, place the box in place on the Shear Box unit and adjust the gap between the lower box and the upper box using the gap adjustment screws on the Shear Box unit. The gap should be adjusted to leave approximately .010 inches (0.2mm) of clearance between

the upper box and the membrane.

- 5.6** Place the unattached end of the membrane through the upper box clamp and retighten.



**When attaching a geosynthetic membrane to the upper box clamp, it may be beneficial to use a heat gun to help form the sample around the clamp, particularly with thicker membranes.**

## **6.0    Preparing the Soil**

---

As previously mentioned, sample preparation is specific to the material being tested and customer requirements. Durham Geo Slope Indicator offers accessories to facilitate sample preparation.

For tests that do not require that sample boxes be full of soil, we offer PVC spacers for use in reducing the overall thickness of soil required. These blocks come in 12 x 16 inch (305 x 406 mm) dimensions for the lower box and 12 x 12 inch (305 x 305 mm) dimensions for the upper box.

In cases where the lower box sample needs to be 12 x 12 inches, we offer an aluminum spacer that measures 4 x 12 inches (102 x 305 mm). This spacer can also be used to help eliminate soil extrusion in the uncovered area of the lower box during testing.



**Sample preparation can and will take a considerable amount of time. Having the appropriate tools and written procedures will simplify preparation and reduce the amount of time spent on this process.**

**A sample preparation table with solid wood or composite top makes an excellent work surface for sample cutting and trimming. Make some aluminum templates to aid in sample preparation. This will help ensure straight cuts and make for a more accurate installation in the clamp rods.**

**A sample preparation table with a solid steel top approximately 18 inches (460 mm) high will facilitate sample loading and compaction.**

## **7.0    Adjusting the Shear Box**

---

There are several adjustments that can be made by the user to ensure proper operation of the Shear Box. If you have further questions about any of the following adjustments, please contact the factory.

## 8.0 Adjusting the Travel

---

The amount of travel available for a test is controlled by the position of the hand wheel in relation to the limit switches. If you need to adjust the travel, perform the following steps:

- 8.1 Be sure the unit is "ON".
- 8.2 After the controller has completed the startup procedure, determine which direction the box needs to be moved. Note: Do not adjust the travel of the box with the sample in place. If the sample has been installed in the Shear Box unit and the Shear Box unit is coupled to the drive unit, you will apply a shear load to the sample.
- 8.3 Use the "F-FWD" (F4) or "F-REV (F5) functions to move the hand wheel into the appropriate position.
- 8.4 Press the "ZERO" (F3) function to establish this point as the new "Zero" or "Home1" position.

## 9.0 Checking the Limit Switches

---

Prior to running a test, it is advisable that the limit switch operation be checked. The limit switches provide a safety system to prevent over travel of the Shear Box. It is advisable that the limit switches be checked daily to ensure proper operation.

### **CAUTION !**

**Improperly operating limit switches can and will result in damage to the equipment.**



**Checking the limit switches involves using the drive unit. Do not perform this check with a sample installed.**

The limit switches may be checked by:

- 9.1 Check that the unit is "ON".
- 9.2 Check that the hand wheel is not resting on either limit switch. If the hand wheel is resting on a limit switch, use the controller to move the hand wheel

away from the limit switches.

- 9.3 With the hand wheel between the limit switches, move the unit with the "F-Fwd" (F4) function. While the unit is moving, manually depress the front limit switch. The unit should stop and the controller should display the message "Upper Limit Reached".
- 9.4 Press (F6) to acknowledge the limit message.
- 9.5 Repeat this procedure by using the "F-Rev" (F5) function.

## 10.0 Measuring the Normal Load

---

Since the sample box measures 12 inches by 12 inches (305 mm x 305 mm), normal load can be estimated directly from the pressure applied to the sample. For example, a pressure of 60 psi (414 kPa) will apply a load of 8640 lbf (38.4 kN) (theoretically) on the sample (60 psi x 144 in<sup>2</sup>) (414 kPa x 93,025 mm<sup>2</sup>). The actual load applied will vary somewhat and tend to be lower than the theoretical load due to inefficiencies in the bladder, side wall friction in the box, and accuracy of the pressure-measuring device. In most cases, this approximation is accurate enough.

If you need to have a more accurate measurement of the applied load, Durham Geo Slope Indicator can supply you with a calibration device that will allow you to correlate pressure readings to exact loads for a 12 inch (305 mm) sample. Please contact the factory for more information.



**Durham Geo Slope Indicator strongly recommends that you calibrate your Shear Box prior to use. Calibrating the device will give you a better understanding of the side wall friction and other conditions in the box that cause a deviation from the "ideal" performance. Additionally, calibration will give more accurate readings and help in interpreting results.**

## MAINTENANCE

As with any mechanical device, the LG-117 will provide its best service if regular maintenance is performed on the unit. While the drive controls and instrumentation are solid state electronics and need little care, the actual drive train and carriage require periodic cleaning and lubrication.

The following items should be addressed regularly:

### 11.0 Daily

---

- 11.1 Check all external cables and connections for integrity. Repair or replace any damaged electrical components.
- 11.2 Wipe any standing water off the unit. Remember, this is an electronic device. Care should be taken to keep the electronics dry and clean.
- 11.3 Clean any soil that has spilled from the sample box.
- 11.4 Check that all clamp bolts, hold downs, material clamps, etc. are in good operating condition and are fully functional. Replace any damaged mechanical components.

### 12.0 Monthly

---

- 12.1 Lubricate the main carriage bearings through the zerk (grease) fitting located at the back of the Shear Box unit near the drain plug for the moisture box. Use a high pressure bearing grease. Contact the factory for details.
- 12.2 Check the bronze piston for damage and lubrication. Lubricate with a high pressure grease as necessary.
- 12.3 Check the moisture box for leaks. Repair as necessary.
- 12.4 Lubricate all threads with a light machine oil (WD-40) to prevent galling.

## TROUBLESHOOTING

### 1.0 Adjusting the height of the Shear Box

---

- 1.1 Roll the drive unit up to the Shear Box.
- 1.2 Using a pair of adjustable wrenches or 3/4 inch open-end wrenches, adjust the legs on the Shear Box until the unit is level with the drive unit and the two units mate. This adjustment should only have to be made once.
- 1.3 If you have multiple Shear Boxes, you will need to check and adjust each unit in the location it will be used.
- 1.4 Once the units are adjusted, they should fit together with very little force.
- 1.5 If you still have problems mating the boxes and the heights are adjusted, apply pressure next to the handle with your foot. Moderate pushing at this point should allow the units to mate.
- 1.6 If this does not work, check for interference of cables, soil, or other materials. If you still have difficulty mating the boxes, contact Durham Geo Slope Indicator for further assistance.

*Hint: Avoid adjusting the height of the drive unit. This height should be constant to allow for interchangeability between Shear Boxes.*

### 2.0 Removing the gap between coupled units

---

If there is a gap between the units when the clamps are locked, adjust the U-bolt on the clamp. This is done by loosening the appropriate nuts and shortening the extension on the U-bolt. If you find it necessary to adjust the U-bolt, please contact the factory as this is an indication there may be a more serious problem with the unit.

### 3.0 Adjusting the tie rod length

---



**It is very important that the tie rods are the same length and distance from the Shear Box when the units are assembled. The tie rods should contact their mating surfaces on the Shear Box simultaneously when the boxes are being assembled.**

The tie rod length is pre-adjusted at the factory to ensure interchangeability between Shear Boxes and drive units. Be aware that any changes to the tie rod setup will affect the interchangeability of the drive unit with other Shear Boxes. Before adjusting the tie rod length, it is important that you inspect the Shear Box tie rod connection to ensure that the discrepancy is not there. If you determine that the Shear Box connection is the problem, please consult the factory for further assistance.

- 3.1 Remove the nut locking plate from the cross bar on the drive unit. Use a 3/16 inch Allen key to remove the socket head screw on the underside of the cross bar that holds the locking plate on.
- 3.2 Loosen the tie rod nuts.
- 3.3 Position the tie rod to eliminate the gap between the end of the drive unit tie rod and the Shear Box tie rod.
- 3.4 Recheck the unit for proper clamping.
- 3.5 Tighten the nuts against the cross bar to lock the tie rods in position.
- 3.6 Reinstall the nut locking plate to prevent the tie rods from changing position. You may have to loosen or tighten the nuts to allow the nut locking plate to mount flush to the cross bar.

### 4.0 Adjusting the LDT

---

If the LDT is used on different boxes, it may need to be adjusted to pick up the travel bar correctly. This adjustment requires the use of a 5/32 inch Allen key.

- 4.1 Mount the LDT to the side of the Shear Box. (Note: This adjustment should only be made with the unit coupled and the Shear Box in the start position.)
- 4.2 Using the Allen key, loosen the black socket head cap screw on the side of the LDT bracket.
- 4.3 Gently pull the LDT into position by grasping the end of the LDT through the open end of the LDT bracket.
- 4.4 Watch the LDT tip through the slot in the side of the bracket and position the tip against the travel bracket.

- 4.5 Tighten the black screw when the tip is in position.

## 5.0 Replacing the Fuse

---

The fuse for the Drive Unit is located in the main power connector on the side of the unit.

- 5.1 Unplug the unit.
- 5.2 Using a screwdriver or your fingernail, lift up on the tab on the fuse holder.
- 5.3 Remove the old fuse.
- 5.4 Replace with the appropriately-sized 5 A fuse.
- 5.5 Replace the fuse holder,
- 5.6 If you experience any problems not covered in this manual or have questions on the setup or operation of this unit, please contact Durham Geo Slope Indicator

## SPECIFICATIONS

The LG-116 is designed and built to meet the needs of the geotechnical engineer when measuring coefficients of friction between a soil and geosynthetic membrane or liner (ASTM D5391-92). This unit conforms to the specifications below. Use of this equipment for other purposes may void any applicable warranties and/or cause damage to the machine or injury to operators. Please read this complete manual prior to operation of this piece of equipment. If you have any questions about the operation or use of this equipment, please contact our Stone Mountain office.

### Operating Characteristics

**Shear Control:** Plain English user interface with digital controls and function key operation. Front panel Emergency Stop with power on indicator light.

**Speed Control:** Microprocessor controlled, closed loop feed-back through an optical encoder and analog output. Speed and direction are controlled digitally through a plain English interface.

**Speed Range:** 0.0001 to 0.2000 in/min (.0025 to 5.1 mm/min)

**Lower Box Travel:** 4 inches (102 mm)

**Normal Load:** 14,400 lbf (45 kN) @ 100 psi (689 kPa) supply air

**Maximum Shear Force:** 10,000 lbf (45 kN)

**Load Measurement:** Electronic measurement with Load Cell (PN E-214) and Digital Readout (BL PN E-415)

**Displacement Measurement:** 4 inch Linear Displacement Transducer (PN E-314)

**Overall Dimensions:** 38 in L x 24 in W x 26 in H (965 x 609 x 660 mm)

**Weight (Shipping):** 700 lb (317 kg)

**Voltage Supply:** 110 v (ac), 60 Hz Standard, 220 V (ac) 50/60 Hz. Option.  
Complies with ASTM (D5321-92)

SPECIFICATIONS

**Air Supply:** 100 psi (1034 kPa) (max.) dry, filtered air

**Maximum Normal Load:** 14,400 lbf @ 100 psi (690 kPa)

**Maximum Shearing Force:** 10,000 lbf (45 kN)

**Shear Plane Gap:** Adjustable up to 318 in (9.5 mm)

**Sample Box Size:** 12 x 12 x 4 (305 x 305 x 102 mm)

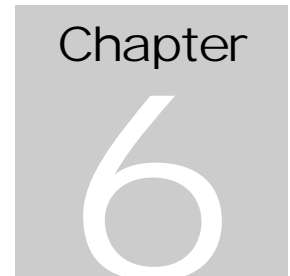
**Lower Box Travel:** 4 in (102 mm)

**Speed Range:** .0001 to .200 in/min (.0025 to 5.1 mm/min)

**CAUTION !**

**This equipment operates on 110 V (ac) and uses a compressed air source to apply normal loads. Daily inspection of electrical and air connections and lines should be conducted to ensure safe operation of this equipment.**

*Durham Geo Slope Indicator makes no warranties of any kind or nature regarding the merchantability or fitness of the products described here for any particular purpose.*



## LIMITED WARRANTY

The LG-116 Direct Shear Machine are guaranteed against defective materials and workmanship for a period of one year from the date of shipment. We will repair or replace such items as may prove defective at our option. Under no condition will we allow labor charges or other expenses to repair defective merchandise without our approval. Durham Geo Slope Indicator makes no other warranties of any kind or nature and all implied warranties or merchantability or fitness for a particular purpose which exceeds the previously stated obligation are expressly excluded. We accept no responsibility for damage or abuse to apparatus due to improper installation or operation. We accept no responsibility for and will not pay for any lost profits incidental, consequential or special damages.

For a complete warranty disclosure, please refer to the printed statement on the back of any Durham Geo Slope Indicator original invoice, or

- visit our web site [www.durhamgeo.com](http://www.durhamgeo.com)
- e-mail [info@durhamgeo.com](mailto:info@durhamgeo.com)
- call **1-800-837-0864** (toll free) or +1 (770) 465-7557

PARTS LISTS AND  
DRAWINGS

## Assembly LG-11225

ITEM	QTY	PART NR	DESCRIPTION
1		4302-01	ASSEMBLY, SEPARATE SHEARBOX
2	2	4275-01	STRAIN ROD ADAPTOR
3	2	4274-01	SPACER, STRAIN ROD
4			
5	2	2791-01	SHEAR BOX SUPPORT BEAM
6	1	2616-87	¼" NPT 105 PSI MAX SAFETY VALVE
7	4	2616-55	HAND KNOB
8	4	2616-56	ADJUSTABLE CLAMPS
9	2	2616-57	SPRING
10	4		½ -13 STUD
11	4	2616-59	WASHER
12	11		3/8-16 BOLT
13	14		3/8 WASHER
14	11		3/8" NUT
15	1	2151-113	¼" NPT NUT
16	1	2850-01	MEMBRANE GRIPPER SUPPORT TOP BOX
17	2	2788-01	MEMBRANE GRIPPER TOP BOTTOM
18	4	4302-18	LEVELING MOUNT
19	2	4302-19	PUSH PULL CLAMP

**Fig 5**

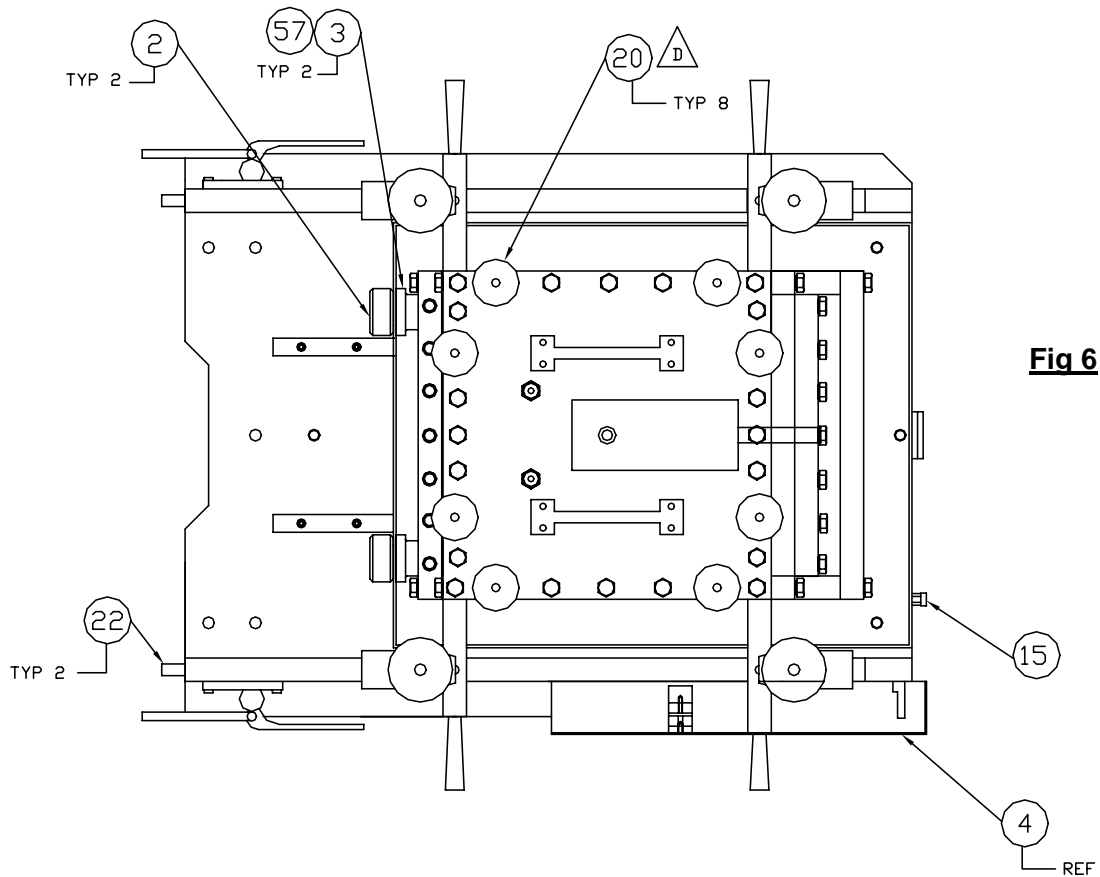
## PARTS LISTS (LG-11225)

20	8	2616-28	HAND KNOB
21	7		3/8-16 BOLT
22	2	4325-01	PIN GUIDE
23	1	2728-01	TOP PLATE
24	2	2616-34	HANDLE
25	10		10-24 FLAT CAP SCREW
26	20		BOLT
27	2	2730-01	TOP SIDES
28	1	4279-01	PLATE SIDE RH
29	2	2729-01	TOP FRONT AND BACK
30	1	2624-01	MOISTURE BOX
31	1	4328-01	PIN
32	2	2627-01	PLATE, SIDE
33	2	2625-01	PLATE
34	6		1/2-13 BOLT
35	35		1/2" WASHER
36	4		3/8-16 STUD 3-3/4" LONG GRADE 8
37	4		3/8-16 BOLT 3" LG
38	4		3/8" DOWEL PIN 1-1/4 LG
39	4	2616-29	EYE BOLT
40	1		1/2-20 NUT
41	4	2616-27	HANDLE
42	1	2787-01	MEMBRANE GRIPPER SUPPORT
43	1	4295-01	PLATE, BEARING LOWER BOX
44	24		1/2-13 BOLT
45	2	600302	RAILS AND BEARINGS
46	2	4322-01	PLATE SIDE
47			
48	1	4321-02	PLATE, REAR LOWER BOX
49	16		M6 SOCKET 35MM LG
50	12		1/2-13 SOCKET BOLT
51	1	4321-01	PLATE FRONT LOWER BOX
52	1	4296-01	BOTTOM PLATE
53	1	4279-02	PLATE SIDE LH FRAME
54	22		10-24 SOCKET CAP SCREW
55	8		1/4-20 SOCKET SCREW
56	4	2871-01	GAP SUPPORT BLOCK
57	2	2404-318	O-RING

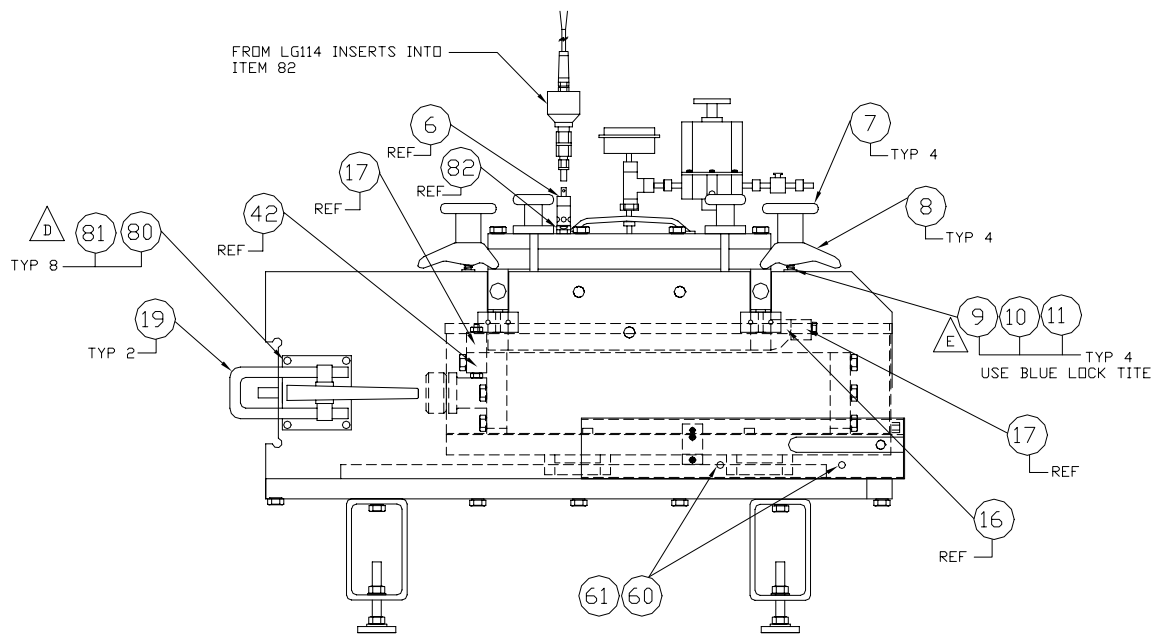
## PARTS LISTS (LG-11225)

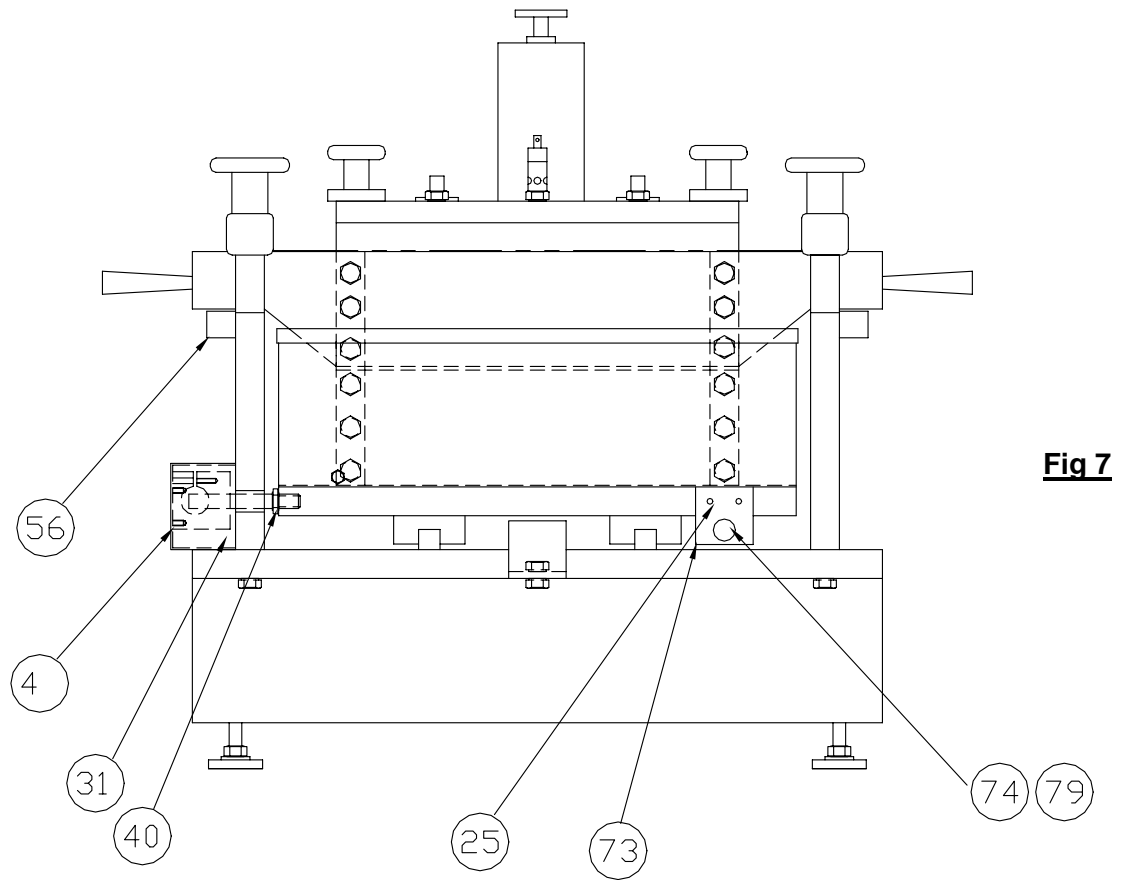
58	2	4323-01	PIN
59	2		1/8 ROLL PIN
60	2	4324-01	PIN TRANSDUCER COVER PLATE
61	2		5/16-18-18 WING NUT
62	1	2616-74	BLADDER
63		600301	BEARING BLOCK
64	1	4332-01	2 X 2 X 1/4" ANGLE
65	1		1/2-13 X 1" LG HEX HEAD BOLT
66	1	2151-005	MALE CONN
67	2	5151-075	1/4 BRASS NIPPLE
68	1	2151-076	1/4 NPT FITTING CAJUN B4-HRN-2
69	1	2151-393	1/4 FEMALE FITTING
70	1	2152-004	2 WAY VALVE
71	1	442005	PRESSURE GAUGE
72	1	E-658	REGULATOR
73	1	4329-01	GREASE FITTING
74	1	2151-372	BULKHEAD FITTING
75	3	2151-282	PUSH ON TUBING
76	4	2151-287	QUICK CONNECTS
77	6		WIRE TIE PADS
78	30	G-52508	1/8 TUBING
79	1	2151-370	GREASE FITTING
80	8		BOLT
81	8		LOCKNUT
82	1	2151-211	FEMALE QUICK CONNEC
83	1	2151-093	MALE CONNECT
84	1	2151-083	SS REDUCER

PARTS LIST (LG-11225)



**Fig 6**

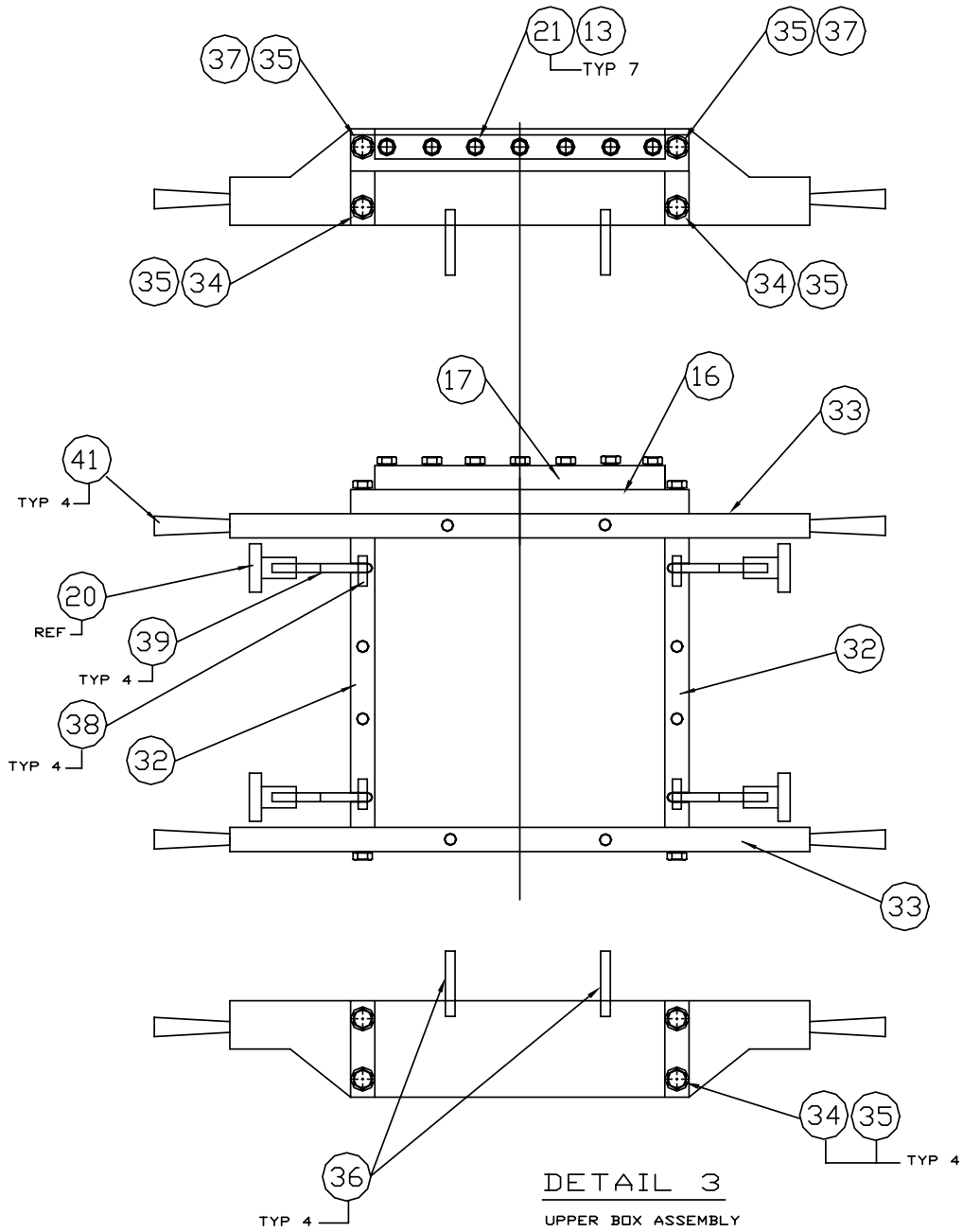




**Fig 7**

**Fig 8**

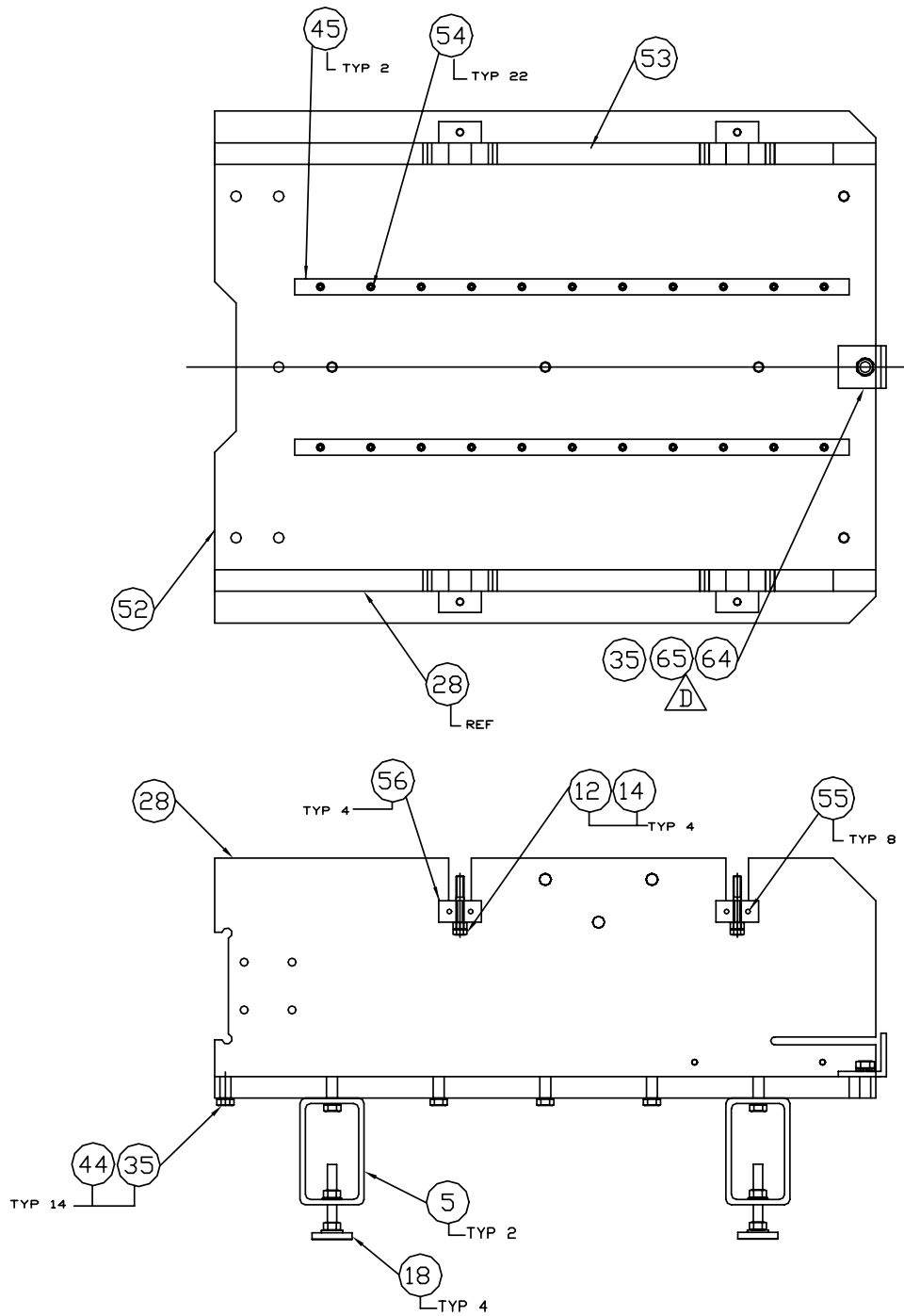
PARTS LIST (LG-11225)



**LG-11225 Upper Box Assembly**



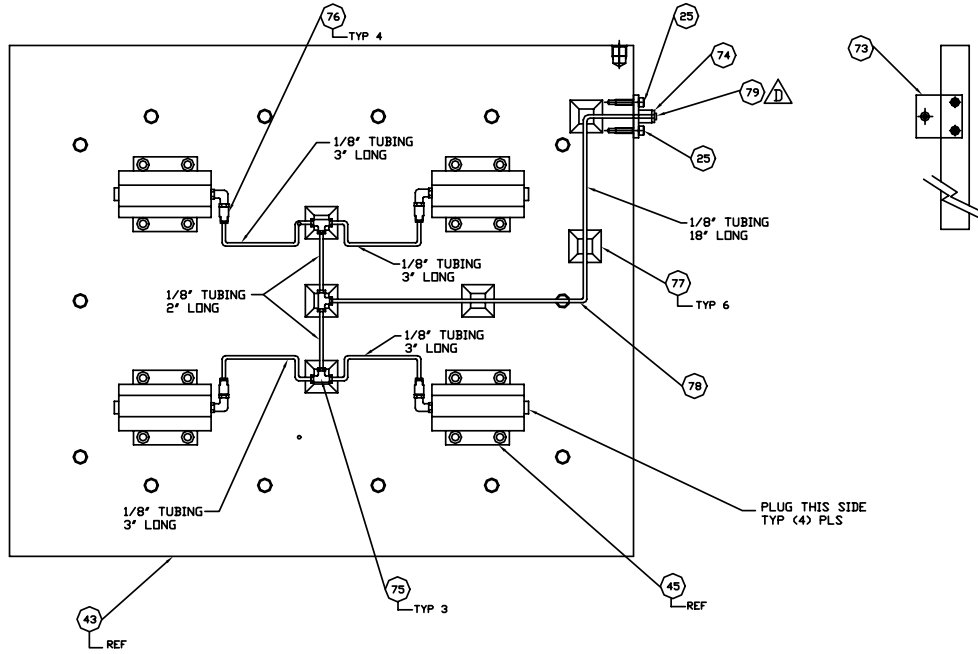
PARTS LIST (LG-11225)



**LG-11225 Frame Assembly**

**LG-11225 Frame Assembly**

PARTS LIST (LG-11225)



**LG-11225 Lubrication Routing Diagram**

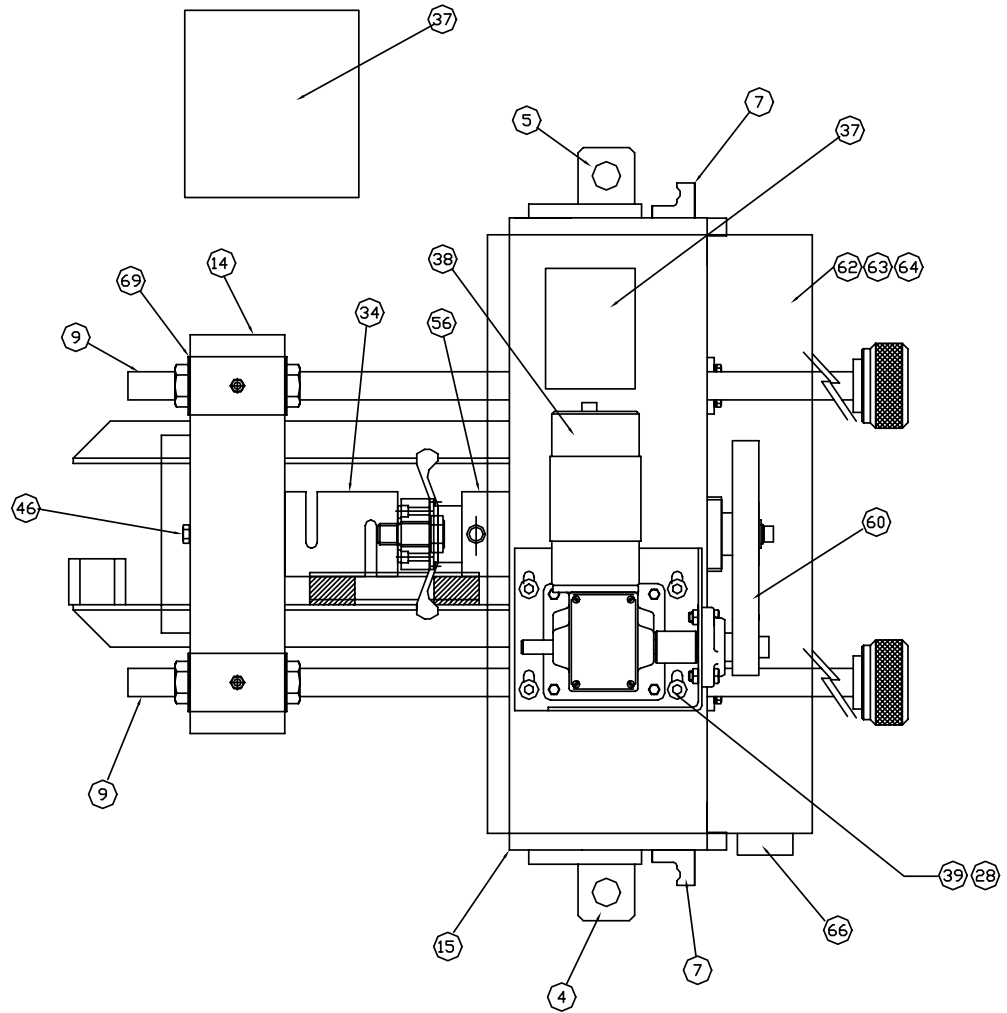
# Assembly LG-117

ITEM	QTY	PART NR	DESCRIPTION
1		4302-01	SEPARATE DRIVE SHEARBOX
2	1	4298-01	MAIN FRAME DRIVE WELDMENT
3	1	4294-01	HANDLE ASS'Y
4	1	4299-01	GUIDE BLACK WELDMENT
5	1	4299-02	GUIDE BLOCK WELDMENT LEFT SIDE
6	1	4285-05	SWIVEL WELDMENT
7	2	4300-01	LATCH PLATE WELDMENT
8	2	4269-01	LATCH BAR
9	2	4277-01	STRAIN ROD MOD.
10	1	4293-01	AXLE TUBE
11			
12	1	4272-01	DRIVE SUPPORT ANGLE
13	2	4342-01	ADJUSTABLE THREADED ROD WELDMENT
14	1	2618-01	UPPER CROSS BEAM
15	1	600933	MECHANICAL DRIVE ASSEMBLY
16	3	4270-01	CLAMPING RODS
17	2	4273-01	COLLAR
18	2	4278-01	LOCKING RING
19			1-14 NUT
20	4		½-13 SCREW
21	8		5/16-18 SOCKET BOLT
22	8		LOCKWASHER
23	1	4313-01	MOD BOLT
24	2		8-32 BOLT
25	4		5/16 BOLT
26	4		5/16 LOCKWASHER
27	4		5/16 NUT
28	16		3/8 LOCKWASHER
29	6		3/8-16 NUT
30	6		3/8-16 BOLT
31	2		5/16 WASHER
32	2		½-13 BOLT
33	1	4308-01	THRUST WASHER

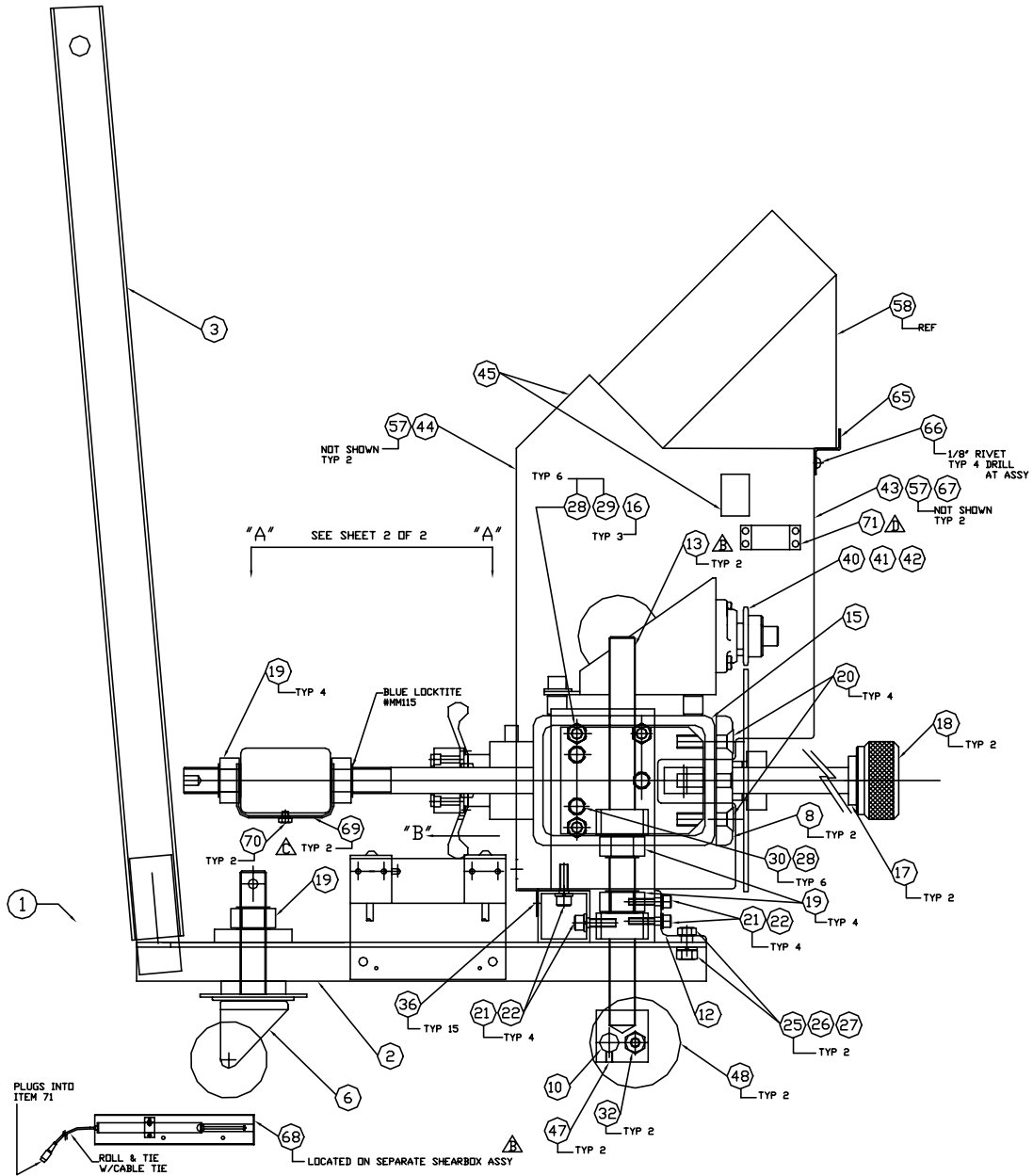
## PARTS LIST (LG-117)

34	1	E-216	LOAD CELL 6000LB
35	1	4309-01	COUPLING
36	15		6-32 BOLT
37		2153-155	TRANSFORMER
38		600935	MOTOR DRIVE ASSEMBLY
39	4		CAP SCREW
40			
41	1		
42			
43	1	4311-01	COVER BACK
44	1	4310-01	,COVER FRONT
45	1	4312-03	WIRING DIA
46	1		¾-16 BOLT
47	2		¼-20 SET SCREW
48	2	4301-48	WHEEL
49	1	4314-01	MOUNTING PLATE
50	2		1/8 ROLL PIN
51		2153-203	LIMIT SWITCH PIN PLUNGER
52	6		10-24
53	4		10-24 NUT
54	4		10-24 LOCKWASHER
55	1	4315-01	HANDWHEEL
56	1	2827-01	PISTON COVER
57		3153-049	CABLE GLANDS
58		2577-02	EASON CONTROLLER
59	2		10-24 WASHER
60	1	600934	BELT TIMING
61			
62		4318-01	VEE LOCATING PLATE
63	4		¼-20 SOCKET HEAD BOLT
64	4		LOCKWASHER
65	1	4319-01	SHELF
66	8		RIVET
67		2153-113	GLAND
68	1	E-314	TRANSDUCER
69	2	4412-01	NUT
70	2		¼-20
71	1	4442-01	CONNECTING BOX ASSEMBLY

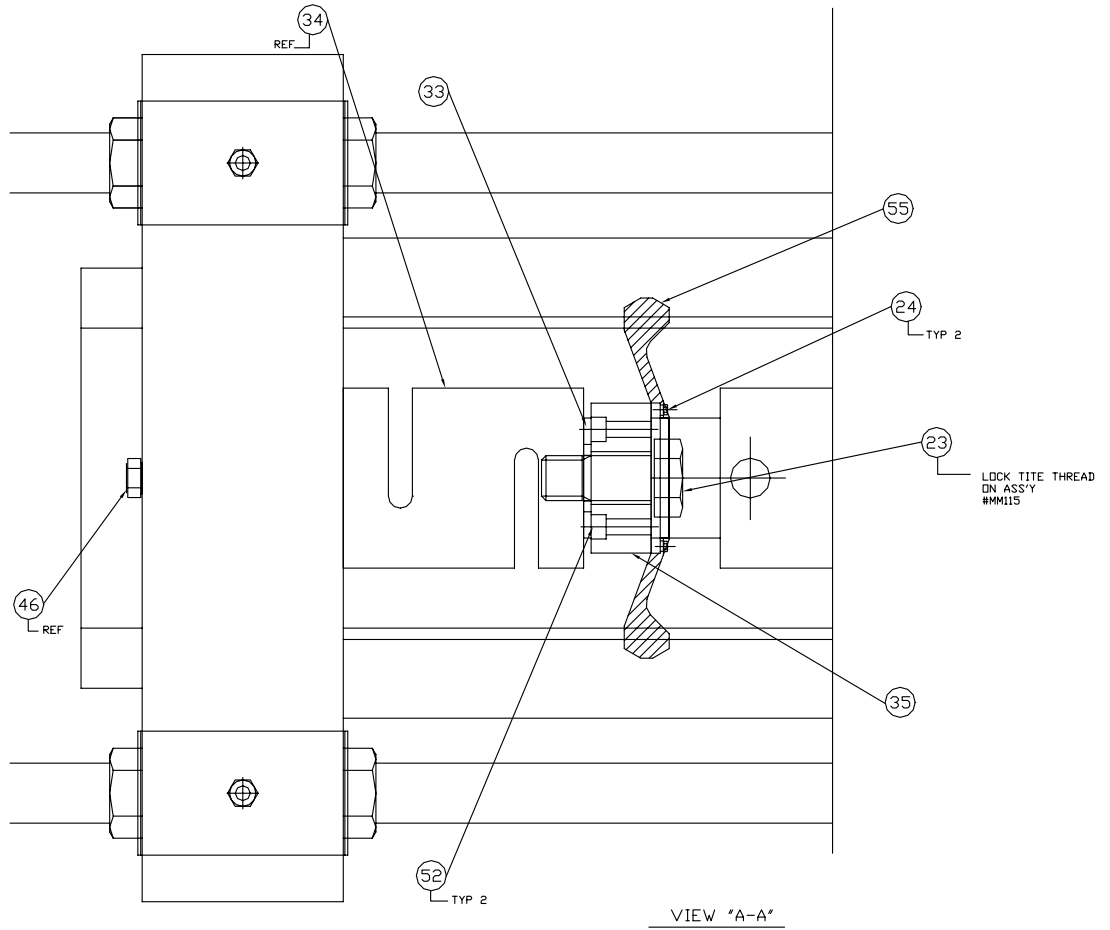
PARTS LIST (LG-117)



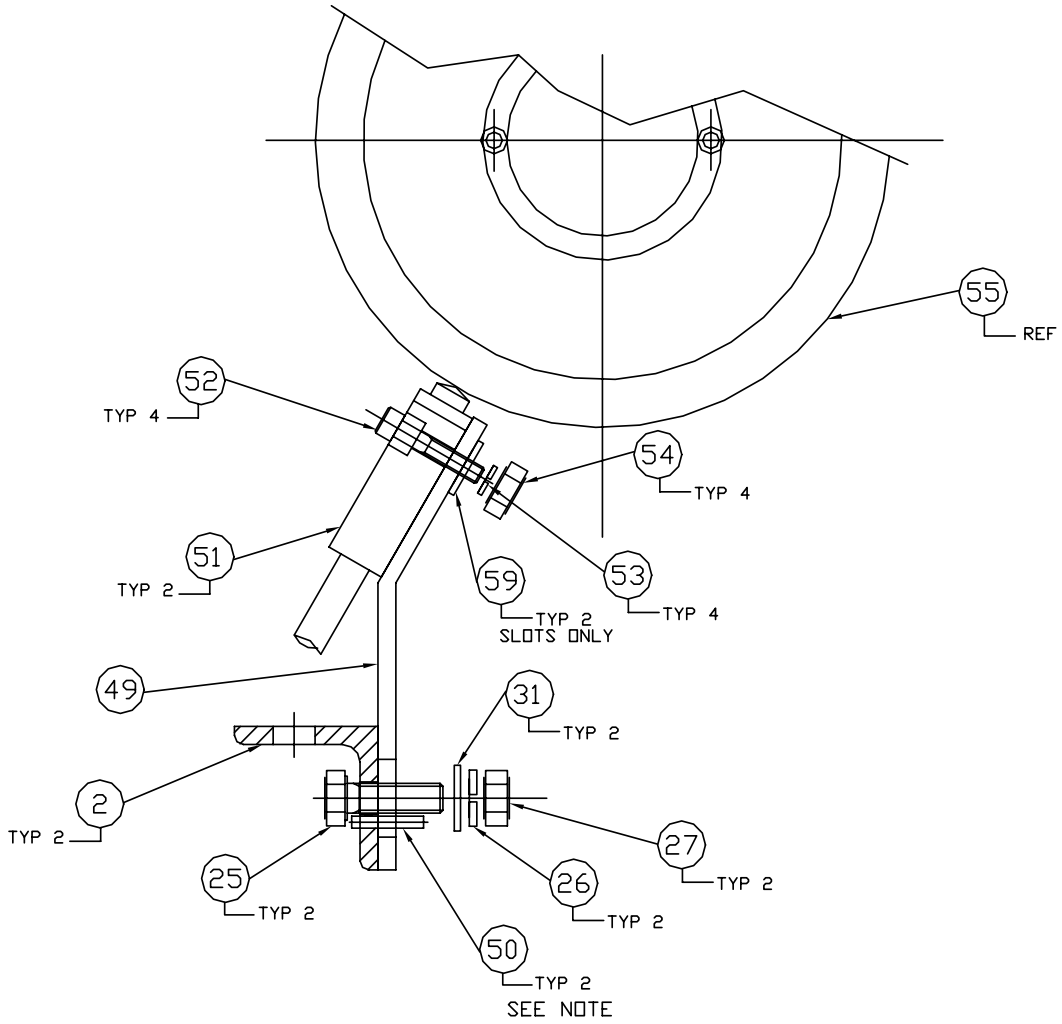
PARTS LIST (LG-117)



PARTS LIST (LG-117)



PARTS LIST (LG-117)



SECTION "B-B"

NOTE:

BOLT ITEM 49 TO ITEM 2.  
 ADJUST ITEM 49 VERTICALLY  
 FOR CORRECT MICRO SWITCH OPERATION.  
 WHEN IN CORRECT POSITION  
 USE 1/8 DRILL TO DRILL HOLE  
 THRU ITEM 49, USING PRE-DRILLED  
 HOLES IN ITEM 2 FOR LOCATION.  
 INSERT ROLL PINS ITEM 50 TO  
 LOCK PLATE IN CORRECT LOCATION.

# WIRING DIAGRAM

ITEM	QTY	PART NR	DESCRIPTION
1	1	600936	MOTOR
2	1	600917	CABLE
3	1	600908	POWER SUPPLY
4	2	2153-295	RECEPTACLES REAR MOUNTING
5	1	2153-045	4 WAY CONNECTOR BLOCK
6	1	2577-02	EASON 1000 CONTROLLER
7	1	300680	15 VOLT POWER SUPPLY

