

Gauge Unpacking Instructions

CM-205 Concrete Load Frame

Important!

When unpacking the gauge, be sure to take out the Styrofoam block that holds the gauge needle down. To do this follow the directions below: (While referring to the drawing below: Side view of the CM-205)

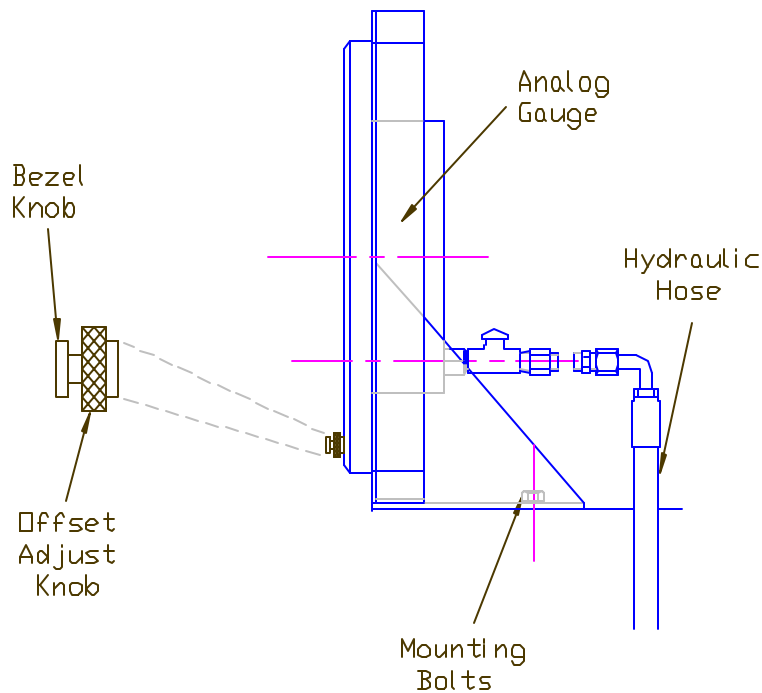

Unscrew the Bezel Knob on the front of the gauge. This will allow you to take off the front of the gauge. With the Bezel Knob out, lift from the bottom of the gauge cover and gently remove the cover. Remove the Styrofoam and reassemble. The gauge is now ready for mounting.

Using the mounting bolts enclosed with the gauge, remove the eyebolt on the top of the frame (After it has been moved to its permanent position!) and mount the gauge with the bolts.

To hook up the hydraulics, simply take the plugs off the hydraulic hose and the gauge. Then connect the hose to the gauge with a wrench.