

Hose Barb Sizes



Exhaust Hose Barb
3/8 in I.D. Buna-N



Air Inlet Push-To-Connect
1/4 in O.D. Tubing.



Fluid Discharge Hose Barb
3/4 in I.D. Buna-N Hose

Warning: All tubing or hoses attached to the pump must be secured with an appropriately sized hose clamp.

Additional Info.

When calling for parts or service, please include the serial number of your pump.



The quick-link chain loop is for securing the pump to the restraining cable.

Additional drawings and parts lists can be found at www.DGSI.info

SRX-R PUMPS

Models TR-974 & TR-976
Quick Start Guide V1.1



Unpacking and Preparation

To remove the pump, separate the packing tape and four staples from the sides of the box, then pull apart the two box halves.

IMPORTANT! You will need to first remove the internal packaging before the pump can be used. A tag will be attached to the pump alerting you of this.



1. Remove the two bolts from the bottom assembly using either a 1/2 in socket or adjustable wrench.



2. Remove the bottom assembly.



Maintenance

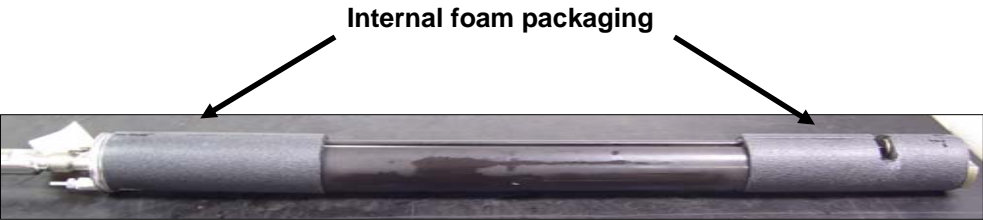

- Now remove the pump body by simultaneously twisting the valve assembly and pulling at the same time until the pump and the body easily separate.
- Once separated, remove the upper-and-lower protective foam packaging.

Note: This packaging is provided to protect both the float and control rod from damage during shipping. DGSi recommends that you save this packaging as well as the box for any future shipping requirements.

To reassemble the pump, follow the above steps in reverse order. When installing the bottom plug, it is recommended that you stand the pump upside-down on the discharge hose-barb, then tighten the two bolts to pull the O-ring seals into place.

Additional drawings and parts lists can be found at www.DGSi.info

To clean the internal components of the pump, remove the housing as outlined in steps 1 – 3 in Packing and Unpacking, then remove the cotter and clevis pins from the bottom assembly before sliding the “T” assembly from the center discharge tube.



The control rod and float can now be removed for cleaning. Remove the barbed fittings to clean the exhaust and air-inlet valves from any debris.



To reassemble the pump, follow the above steps in reverse order.

Warning: Any further disassembly should be carried out by DGSi.

Note: Some parts listed are sold only as a kit.

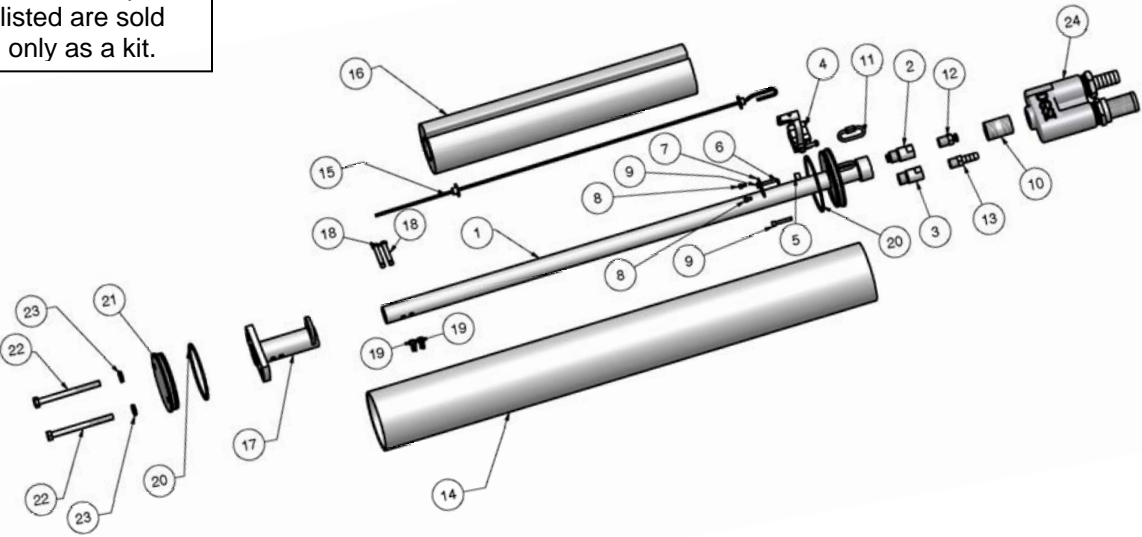

* Parts for model TR-976 differ from items listed. For complete parts list, visit www.durhango.com.

No.	Qty	Part #	Description
1*	1	603221	Pump Head Weldment, Short
2	1	603012	Air Valve Cartridge
3	1	603026	Exhaust Valve Assembly
4	1	603024	Air / Exhaust Valve Assembly
5	1	601968	Magnet, .375" Dia. X .25" Thick HT
6	1	2404010V	O-Ring, 010 V
7	1	603003	Magnet Cover Plate
8	2	603004	Cap Screw, 6 – 32 x 1/4" Long
9	2	603015	Cap Screw 8 x 32 x 1" S.S.
10	1	603017	Close Nipple 1/2" S.S.
11	1	918521	Quick Link 5/32" S.S.
12	1	2151167	1/2" Tube x 1/2" MNPT Tube Fitting
13	1	301040	Brass Hose Barb, 3/8 Barb x 1/2" MNPT
14*	1	603220	Pump Body, Short
15	1	603234	Control Rod Assembly, Short
16	1	602874	Float Nitrile
17*	1	602992	Bottom T Assembly
18	2	603020	Pin, Clevis, 1/4" x 1 7/16" Long S.S.
19	2	603182	Hairpin Cotter Pin
20	2	2404151V	O-Ring, 151 V
21	1	603143	Closed Bottom
22	2	603013	Bolt, 5/16" x 3 3/4" Long
23	2	603022	Sealing Washer, 5/16" S.S.
24	1	603245	Top Inlet Valve Assembly