

TR-121 EVACUATOR II PUMP SYSTEM

Version 1.1

Operator's Manual

DURHAM GEO-ENTERPRISES

Operating Instructions

© 1997 Durham Geo-Enterprises, Inc.
2175 West Park Court • PO Box 870907
Stone Mountain, GA 30087 USA
Telephone 770.465.7557 • Fax 770.465.7447
Email: garydurham@aol.com
Printed in the USA

TABLE OF CONTENTS

- Introduction p.3
- System Components p.4
- Principles of Operation p.8
- Operating Instructions p.9
- Maintenance/Troubleshooting p.12
- Appendix A p.14
 - Air Consumption
- Illustrations
 - Figure 1 – TR-121 Bottom Loading Pump p.17
 - Figure 2 – TR-123 Top Loading Pump p.18
 - Figure 3 – TR-121 Installation p.19
 - Figure 4 – TR-123 Installation p.20
 - Figure 5 – 2” Evacuator II Installation Set-up p.21
 - Figure 6 – Pump w/Pulse Counter Installation p.22
 - Figure 7 – Pump w/SVE Manifold Installation p.23
 - Figure 8 – Pump w/Pulse Counter and SVE Manifold p.24

INTRODUCTION

The Durham Geo EVACUATOR™ II controllerless pneumatic pump is available with a bottom loading feature, or in a top loading only version to deliver fluids to the surface. The pump is designed to fit in groundwater wells as small as 2 inches (51 mm) in diameter. The EVACUATOR™ II uses a down-well pneumatic logic system to cycle the pump automatically, maintaining a constant groundwater depression level.

This manual introduces the EVACUATOR™ II and provides step-by-step guidelines for successful installation and operation. Please read this information carefully before using the pump and keep the manual handy for field reference. Failure to read this manual prior to installation and operation may result in voiding the warranty. If you have any questions about the installation or use of these pumps or the contents of this manual, contact Durham Geo at:

Telephone

1-800-837-0864

or

1-770-465-7557 (Outside the US)

Fax

1-770-465-7447

System Specifications

- Pump Dimensions – 42.25” Length (1073 mm) (Top Loading)
34.25” Length (870 mm) (Bottom Loading)
- Pump Weight – 6 lbs (2.72 kg)
- Operating Pressure – 20 psi minimum (138 kPa) to 100 psi (689 kPa) maximum
- Operating Temperature - 120° F (49° C) maximum
- Air Requirements – 5 micron filtered, dry air (dew point 0° F (-17° C))
- Pumping Volume – Top Loading: 2.5 gpm @ 10 psi TDH (9.5 L/min @ 6.9 kPa)
Bottom Loading: 4.0gpm @ 10 psi TDH (15.1 L/min @ 6.9 kPa)
- Maximum Operating Depth – 225’ (68 m)
- Materials – T304 stainless, brass, Viton®, Teflon®, Nylon® and Nitrophyl® float (other materials available on request)

SYSTEM COMPONENTS

This unit has been packed to help insure that it arrives at your job site ready for installation. However, occasionally circumstances beyond our control may result in damage to the equipment during shipment. Please examine all packages for signs of external damage as you unpack the contents. Make a note of any damage, and contact Durham Geo-Enterprises, Inc. immediately.

As you unpack the Evacuator II, you will find the following components:

1. EVACUATOR™ II pump (Fig. ½)
2. 2 inch (51 mm) diameter Well Clincher
3. 5-micron filter regulator assembly
4. Spanner wrenches
5. Hose Clamps (2 ea)

Available Accessories include:

1. Precut bundled hose for easy installation
2. 6 inch well clincher adapter
3. 4 inch well clincher adapter
4. SVE Attachment
5. Pulse Counter

If you are missing any components or want to place an order for an accessory, please contact your Durham Geo-Enterprises representative or call our Stone Mountain office at:

Telephone

1-800-837-0864

or

1-770-469-7557 (Outside US)

Fax

1-770-465-7447

EVACUATOR™ II

This manual addresses both the TR-123 (Top Loading) and TR-121 (Bottom Loading) pumps.

The EVACUATOR™ II (Fig. 1) consists of a stainless steel pump assembly with the intake port at the bottom (TR-121), or at the top (TR-123). There are color coded connections for air supply, air exhaust, and product discharge tubing. The fluid intake port at the bottom consists of a Buna-N check ball in a stainless steel seat. A Nitrophenyl® float riding on a stainless steel carrier provides the signal which cycles the pump.

WELL CLINCHER

The EVACUATOR™ II pump system comes standard with a 2" pipe diameter Well Clincher which is used at the well head for pump support, air supply and fluid discharge connections. There is also an optional adapter for 4" and 6" pipe diameter wells. The clincher provides a watertight seal which isolates the well environment from surface contaminants.

The Well Clincher is made of machined PVC so that the inner diameter matches the outer diameter of 2" PVC well monitor pipe. The Well Clincher features an o-ring seal for vacuum applications. It comes complete with all the brass fittings required to connect to the EVACUATOR™ II pump system, as well as a stainless steel chain and connector to attach a pump support cable.

HOSES

The following is a description of the hoses required to operate the EVACUATOR™ II pump system:

1. The down-hole assembly (TR-730) is bundled, PVC wrapped, and color-coded to simplify installation. The bundled tubing includes:
 - a white, ½ inch (13 mm) polyethylene air supply hose
 - a black 1/8 inch (3.2 mm) Nylon® pilot pressure hose
 - a black 5/8 inch (19 mm) Nylon® discharge tube
 - a green 1/8 inch (3.2 mm) Nylon® logic level air supply hose
 - a blue 1/8 inch (3.2 mm) Nylon® air exhaust hose for the pump logic

All 1/8 inch lines and their corresponding fittings are color-coded to help insure proper connection. The Durham Geo bundled tubing assembly is designed and custom-made for the Evacuator™ II.

2. The ½ inch air supply and 5/8 inch fluid discharge connections on the Well Clincher are sized to work with the Durham Geo bundled tubing.

AIR SOURCE

The air consumption rate of the EVACUATOR™ II pump system will depend on several site-specific variables including operating air pressure and total fluid recovery rate. A worksheet in Appendix A shows the air consumption for the pump system. Once the air consumption rate has been determined, any air compressor dealer will be able to specify the appropriate size compressor (and air dryer if applicable).

The EVACUATOR™ II pump system uses compressed air to displace the water in the pump and force it to the surface. Due to the wide variation in compressor requirements for each site, an air source is not included with the EVACUATOR™ II pump system. When determining the appropriate size for your system compressor, you need to consider the following factors:

1. The number of pumps to be installed
2. The total length of air line running to the pumps
3. The diameter of the air lines
4. The system operating pressure
5. Other air requirements that the complete remediation system will impose
6. Operational depth of the pumps

For more information refer to Appendix A or contact Durham Geo's technical service staff. We can help size a compressor appropriate for your needs.

Notice

Durham Geo strongly recommends using clean, dry air to prolong the life of the EVACUATOR™ II and to prevent further contamination in the groundwater. In high humidity and freezing temperatures, the addition of an air dryer may be required to avoid damage to the system. Moisture in the air supply lines may result in premature failure of the control circuit.

AIR FILTRATION

A 5 micron particulate and .01 micron coalescing filter with auto drain assembly is included with each EVACUATOR™ II pump system. This assembly should never be submerged in water. It must be installed at the well head to assure that clean air is supplied to the EVACUATOR™ II within its working pressure range of 20 psi to 100 psi (138 kPa to 690 kPa).

CAUTION

Air pressures greater than 100 psi (690 kPa) applied to the EVACUATOR™ II may damage the pneumatic logic system and void the warranty.

PRINCIPLES OF OPERATION

The EVACUATOR™ II pumps fluids by air displacement with compressed air forcing the fluids out of the pump chamber to the surface.

The EVACUATOR™ II operates in two stages: the ON, or discharge stage, and the OFF, or filling stage. The stages are controlled by a float which rides on top of the fluid inside the pump chamber. When the pump is in the OFF stage, the inlet valve is open and fluid enters the chamber. As the chamber fills, the float reaches the top of its travel, sending a signal to the control valve and putting the pump in the ON or discharge stage. During the ON stage, pressurized air closes the inlet valve forcing the fluid to evacuate the pump chamber through the discharge pipe.

When all of the fluid has been pumped from the chamber, the float, which has now reached its lower limit, signals the control valve to stop pressurizing the chamber. This allows the chamber to exhaust, opening the inlet and beginning the OFF stage.

This cycle is repeated as rapidly as the pump fills up with fluid; this is how the EVACUATOR™ II automatically determines its own pumping rate. If needed, the pumping rate can be decreased by regulating the discharge from the pump at the surface using a gate valve.

The EVACUATOR™ II is designed to maintain a drawn down fluid level in the well, even with the top of the pump. This level is 27 inches (762 mm) from the bottom of the pump and is located approximately at the seam that separates the pump top from the pump chamber. If the EVACUATOR™ II is being used in the top loading only configuration, the fluid level will be maintained 37 ¾ inches (959 mm) from the bottom of the pump, flush with the top of the pump (at the level of the inlet valve).

The standard EVACUATOR™ II pump system, configured for bottom loading, is designed to pump a maximum of 4 gpm (15 Lmin). The EVACUATOR™ II with the top-loading only feature will pump a maximum of 2.5 gpm (9.5 Lmin).

INSTALLATION AND OPERATION

The EVACUATOR™ II may be used to remove fluids from wells that are 2 inches (51 mm) in diameter or larger. The location of the pump relative to the air supply and the recovery system on the surface will differ from site to site. Similarly, the length of discharge and air hoses required to connect the pump may vary. Otherwise, the installation and operation of the EVACUATOR™ II are essentially the same for any application.

WARNING:

Any electrical components used in an explosive atmosphere must be located in compliance with Chapter 5 of the National Electrical Code and any other local codes. This would apply to electrically powered air compressors as well.

INSTALLATION PROCEDURE

The following steps outline the hose connectors when using the bundled hose assembly. For installations with non-standard hoses (not recommended), please call your Durham Geo representative:

Determining the Hose length:

1. Determine at what depth the pump will be installed. Measure from the top of the pump head (at the depth the pump will be set) to the top of the well casing and add 6 inches (152 mm) to the cut hose length.
2. Place the bottom half of the Well Clincher on the top of the recovery well pipe. Make sure that the top of the recovery well is smooth and straight. The Well Clincher should fit snugly.

Connecting to the Pump

3. Pump Logic – Attach the green (air supply), blue (air exhaust), and black (air pilot) 1/8 inch (3.2 mm) color coded tubing to the matching colors on the pump head by pushing the tubes firmly into the matching color coded fitting until the hose bottoms in the fitting. Pull gently on the hose to insure that it is secure.

Discharge

Top Loading Pump – Cut the discharge tubing 9.5” (241 mm) shorter than the rest of the hoses. Place one of the supplied hose clamps over the end of the discharge tube and tighten the clamp. Check that the connection is secure by pulling firmly on the discharge hose.

4. Air supply – Attach the natural white color ½-inch (12.7 mm) air supply to the ½-inch (12.7 mm) brass barb fitting on the pump head. Use the supplied hose clamp to tighten the tube on the barb. Pull gently on the hose to insure proper connection.
5. **Notice: A stainless steel safety cable should be attached to the EVACUATOR™ II in order to minimize the tension on the down-hole hoses. The down-hole hoses are not designed to support the weight of the pump. A stainless steel loop can be found on the top of the pump and a stainless steel chain and connector on the bottom side of the Well Clincher. The safety cable should be attached between the loop and the connector.**

Connecting to the Well Clincher

1. Connect the down-hole hoses and safety cable to the underside of the Well Clincher top (Figure 4).
2. Cut the tube ends (using a tubing cutter or sharp knife) square.
3. Attach the 1/8-inch (3.2 mm) green (Fig. 2, Item 12, air supply) and black (Fig. 2, Item 11, air pilot) lines to the matching color-coded push-in fittings by pushing them firmly into the fittings until the hoses bottom. To release, push the collar of the fitting down and pull tubing out.
4. The 1/8-inch (3.2 mm) blue exhaust line will remain loose on the underside of the Well Clincher.
5. Attach the white air supply line to the ½ inch quick lock connector fitting (Fig. 2, Item 10)
6. Attach the stainless steel restraint cable to the chain connector on the stainless steel chain. Adjust the tension on the stainless steel cable by moving the chain connector up or down on the stainless steel chain.
7. Lower the EVACUATOR™ II down the well and secure the top cap of the Well Clincher to the bottom coupling (which was previously attached to the well).

8. Connect the fluid discharge line to the 5/8 inch barb on top of the Well Clincher. It is recommended that a ball valve and swing check valve be installed in-line between the Well Clincher and the discharge line coming to the well to prevent backflow of fluids down the well. This unit can be purchased from Durham Geo as our Product Valving Kit (TR-756).

NOTE: All 1/8 inch (3.2 mm) lines are nylon, and the 1/2 inch (12.7 mm) line is polyethylene. The discharge hose is Nylon®, and the outer jacket of the bundle is PVC. Check chemical compatibility with well fluids **BEFORE** installation.

9. Attach the filter regulator assembly to the side of the Well Clincher. **THE FILTER ASSEMBLY MUST BE MOUNTED HORIZONTALLY TO WORK PROPERLY.**

Notice

Installation of the Filter Regulator assembly should be accomplished to remove any danger of the FRL being submerged under water during operation. Submergence of the FRL may result in damage to the unit and void any warranties.

10. Connect the main air supply line to the filter regulator assembly.

NOTICE

Purge air lines between compressor and pump regulator before connecting air lines to the filter/regulator assembly.

11. Connect the outlet of the filter regulator assembly to the air supply line on the top of the Well Clincher.
12. Adjust the air supply at the regulator/ filter assembly to the appropriate working pressure (20- 100 psi).
13. Open the air supply valve to begin pump operation.

WARNING

THE PUMP IS NOT DESIGNED TO BE AN AIR RESERVOIR. DO NOT PRESSURIZE PUMP OUTSIDE OF WELL.

Maintenance and Troubleshooting

MAINTENANCE

Maintenance of the Evacuator II actually occurs during system specification and set-up. The most important things you can do to insure trouble free operation of your pumps are:

1. Correctly size the compressor for your installation.
2. Specify and install an air dryer to insure that the pumps are receiving clean, dry air.
3. Install the Filter/Regulator assembly above the level where water would collect in the well vault.
4. Change the filter on the Filter/Regulator assembly as often as required to insure clean air is being sent to the control circuit.

TROUBLESHOOTING

Even the best installations can sometimes experience start-up problems. The following section provides some tips for troubleshooting potential problems.

Problem – Pump not operating

- Is proper air pressure applied to the pump?
- Be sure all lines are connected to the clincher and pump correctly.
- Check for crimped lines from clincher to pump.
- Is discharge line restricted?
- On top loading pump, check upper intake. Is it clogged or sticking?
- Are the filters clogged in the filter regulator unit?
- Check for sticking float (clean stainless steel tubes inside of pump).
- Control unit may be faulty (see testing pump control unit).

Problem – Pump blowing air into discharge line momentarily at end of pump cycle

- Lower operating pressure of the pump.
- Check for obstructed air discharge from pump control.
- Control unit may be faulty (see testing pump control unit).

Problem – Pump blowing air into discharge line continuously

- Check for sticking float (clean stainless steel tubes inside of pump).
- Check for obstructed air discharge from pump control.
- Control unit may be faulty (see testing pump control unit).

Problem – Air blowing in the well continuously

- Upper intake valve may not be closing on the pump (low pump pressure, damaged check ball, or foreign object in upper intake).
- Check for loose or broken air line above the pump.
- Check the gauge on the filter/regulator assembly. The operating pressure should not drop below 20 psi (138 kPa) during operation.

TESTING PUMP CONTROL

- Turn air off to the pump and remove the pump from the well. Disassemble the bottom and body from the pump.
- Disconnect the tube going into the back fitting on top of the pump, and connect a pressure gauge into this fitting.
- Slide the float to the bottom end of the stainless steel tube and restore air pressure to the pump.
- Slide the float to the float stop next to the pump head. At this point the pressure gauge should indicate line pressure equal to that at the regulator.
- Slide the float to the center of the SS tube and check the pressure gauge again. The pressure should remain unchanged.
- Slide the float to the bottom stop. The pressure should release from the control unit with no pressure indicated on the pressure gauge.

APPENDIX A

AIR CONSUMPTION

The EVACUATOR™ II pump uses compressed air to transport fluid from a recovery well to the surface. The volume of compressed air required to operate the pumps is dependent on three factors:

1. Number of EVACUATOR™ II pumps increases, the compressed air consumption rate will also increase.
2. Operating air pressure of the pumps
3. Pumping rates (gallons or liters per minute)

As the operating air pressure of the EVACUATOR™ II pump is increased, the volume of air consumed during each pump cycle increases. The following table outlines the air consumption rate per cycle of the EVACUATOR™ II at different operating air pressures.

TABLE A-1

OPERATING AIR PRESSURE		COMPRESSED AIR CONSUMPTION RATE	
<u>PSI</u>	<u>KPa</u>	<u>(ft³/cycle)</u>	<u>Cm³/cycle</u>
60	414	0.83	14
70	483	0.94	15
80	552	1.05	17
90	620	1.15	19
100	690	1.26	21

Very few sites will require an operating air pressure of 100 psi (690 kPa), but it is recommended that the highest air consumption rate, 1.26 ft³/cycle (21 cm³/cycle), be used when determining the total compressed air consumption for the site.

The pumping rate required to achieve the desired water table depression will directly influence the compressed air consumption rate. The 2" EVACUATOR™ II pumps .18 US gallons (.68 l) of fluid/cycle. Each pump has a maximum fluid flow rate of 4.0 gpm (15.1 l/min) with the bottom loading version. The pumping rate of each recovery well should be determined so that the total pumping rate of the site can be calculated.

The following questions will help determine the compressed air consumption rate:

1. How many recovery wells will be used on the site?
2. What is the pumping rate for each recovery well?
3. What is the total pumping rate for this site? (add pumping rates from question 2.)
4. Use the total pumping rate calculated in question 3 in the following formula to determine the air consumption rate.

$$\text{AIR CONSUMPTION [ft}^3\text{/min]} = \frac{\text{Total Pumping Rate [gal/min]}}{10.0} \times \text{Air consumption per cycle (ft}^3\text{) at operating pressure*}$$

$$\text{AIR CONSUMPTION [cm}^3\text{/min]} = \frac{\text{Total Pumping Rate [L/min]}}{40} \times \text{Air consumption per cycle (cm}^3\text{) at operating pressure*}$$

The operating air pressure will depend on the amount of force the EVACUATOR™ II will need to push the water from the pump to the remediation equipment on the surface (total dynamic head). As the operating air pressure is set higher, more air will be consumed with each cycle of the pump due to the physical characteristics of compressed air.

For example, at an operating pressure of 60 psi (414 kPa), the EVACUATOR™ II will consume 0.8ft³ (14 cm³) of air/cycle. At an operating pressure of 100 psi (690 kPa), the EVACUATOR™ II will consume 1.26 ft³ (21 cm³) of air/cycle. The total water recovery rate will dictate how often the pump cycles.

If you have any questions about sizing compressors, number of pumps required for your site, etc., please call Durham Geo's technical service staff in Stone Mountain. They can be reached at:

Telephone

1-800-837-0864

or

1-770-465-7557

Fax

1-770-465-7447

2" Evacuator II
Bottom Loading Pump (TR-121)
Figure 1

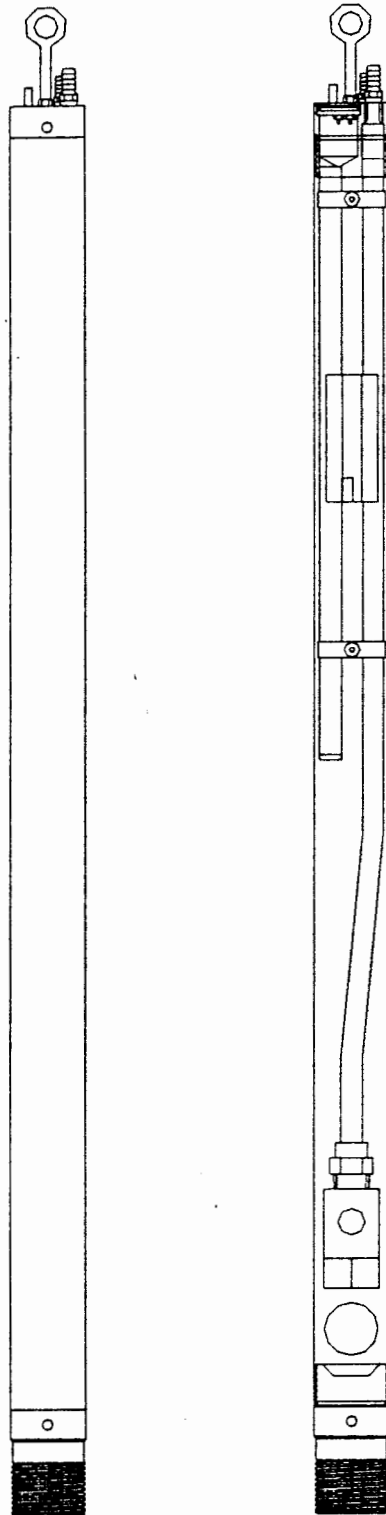

2" Evacuator II
Top Loading Pump (TR-123)
Figure 2

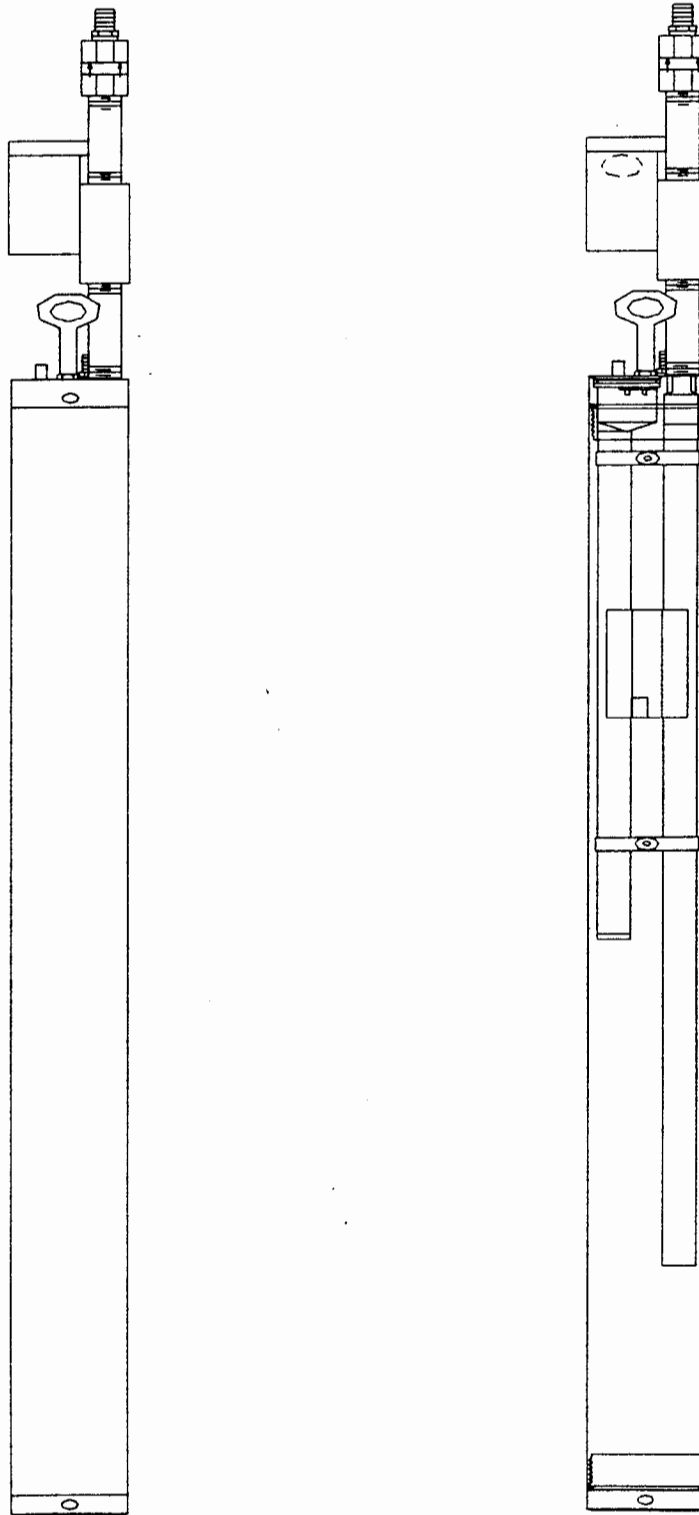

**Bottom Loading Pump
Installation
Figure 3**

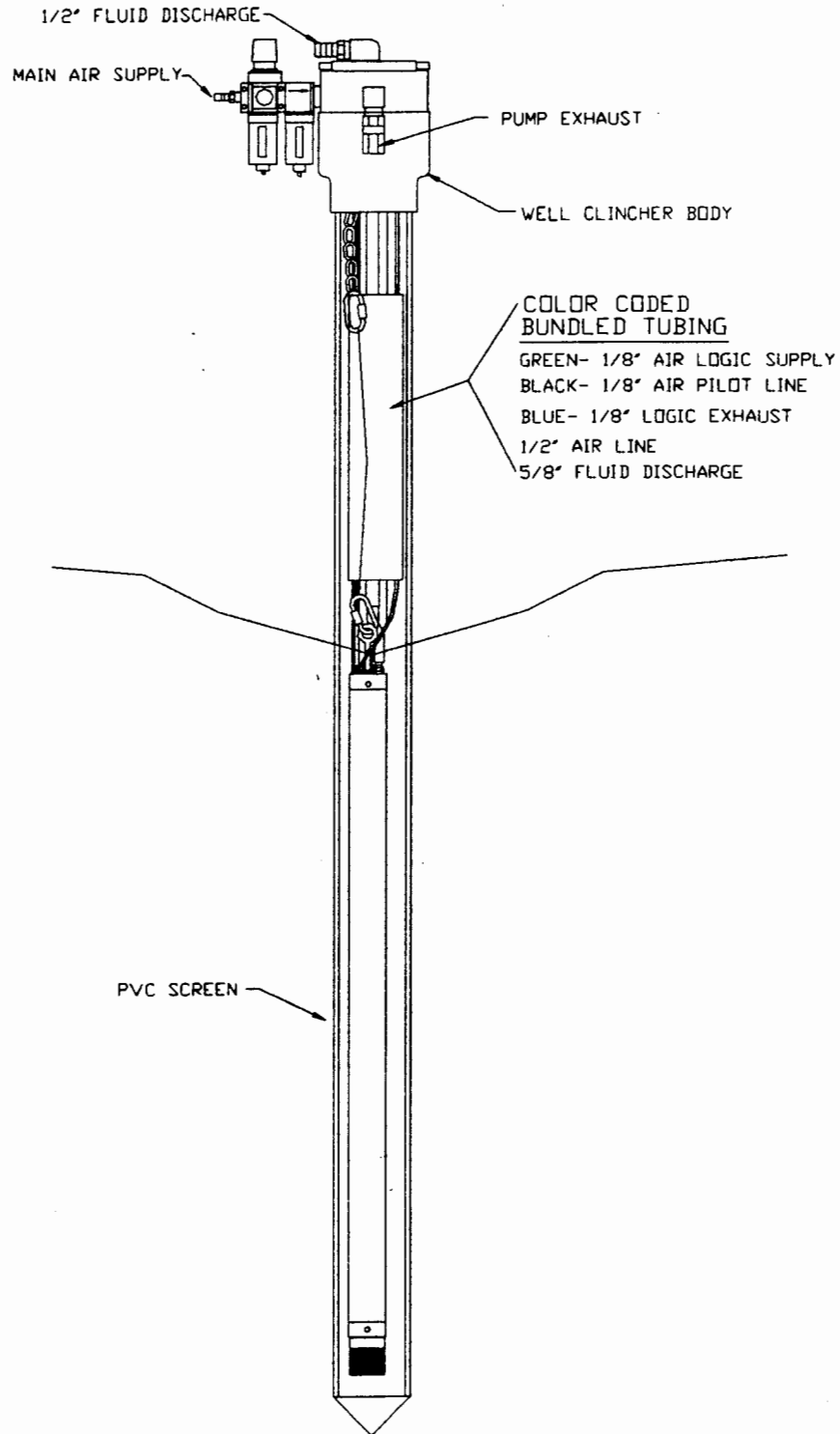

**Top Loading Pump
Installation
Figure 4**

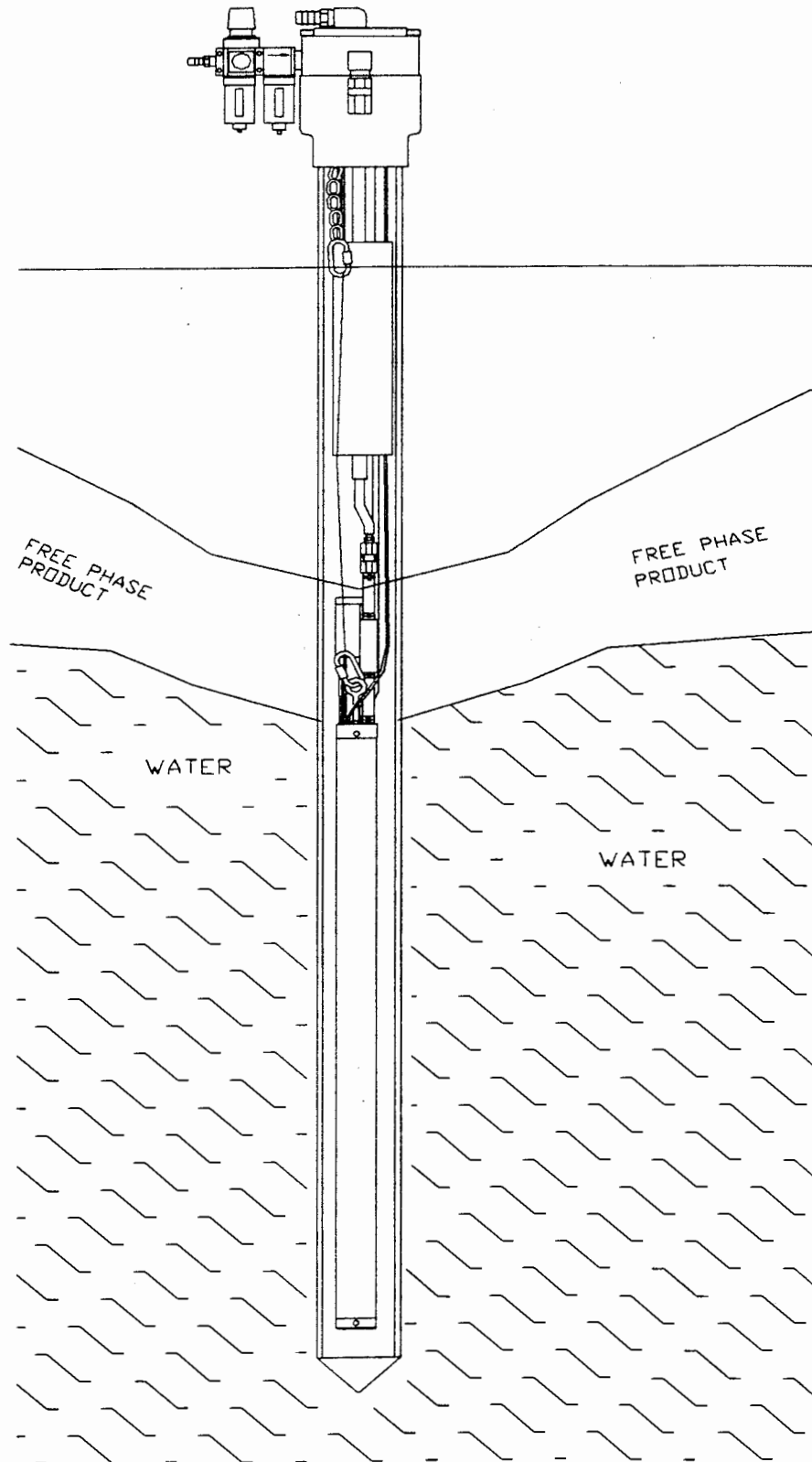

2" Evac II Installation Set-up

Figure 5

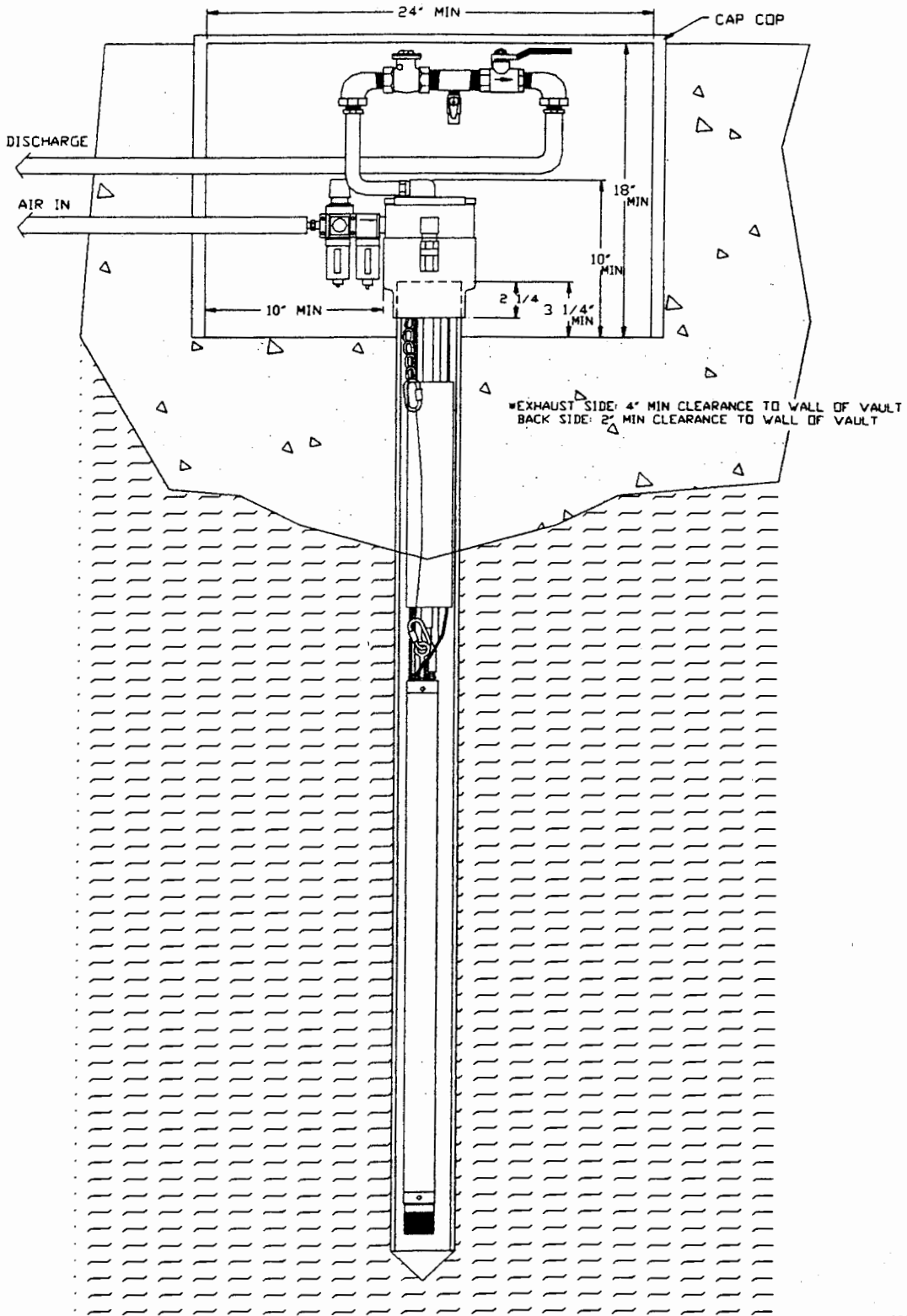

(LEVEL12)

Pump w/ Pulse Counter Installation Set-up
Figure 6

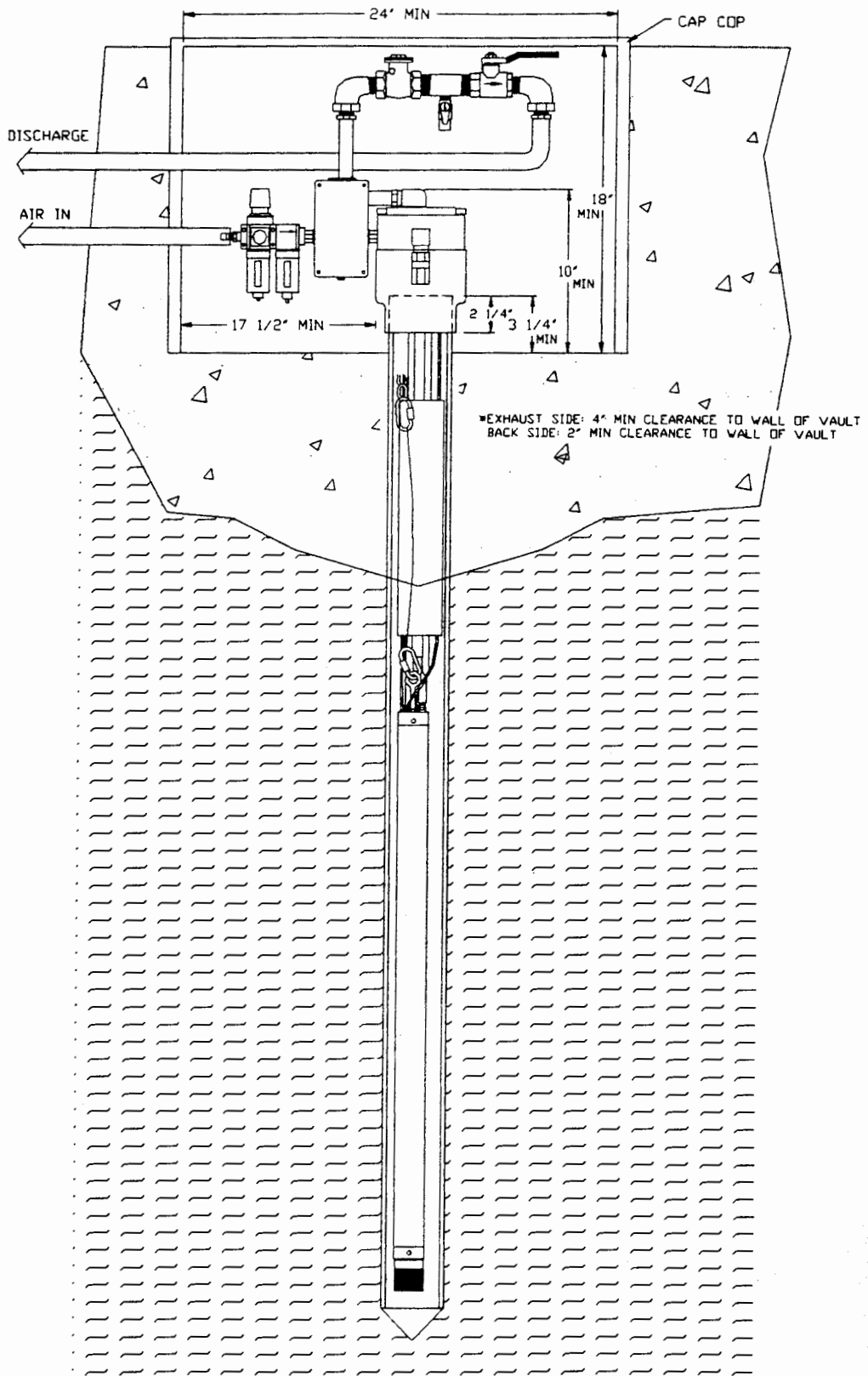

Pump w/ SVE Manifold Installation Set-up

Figure 7

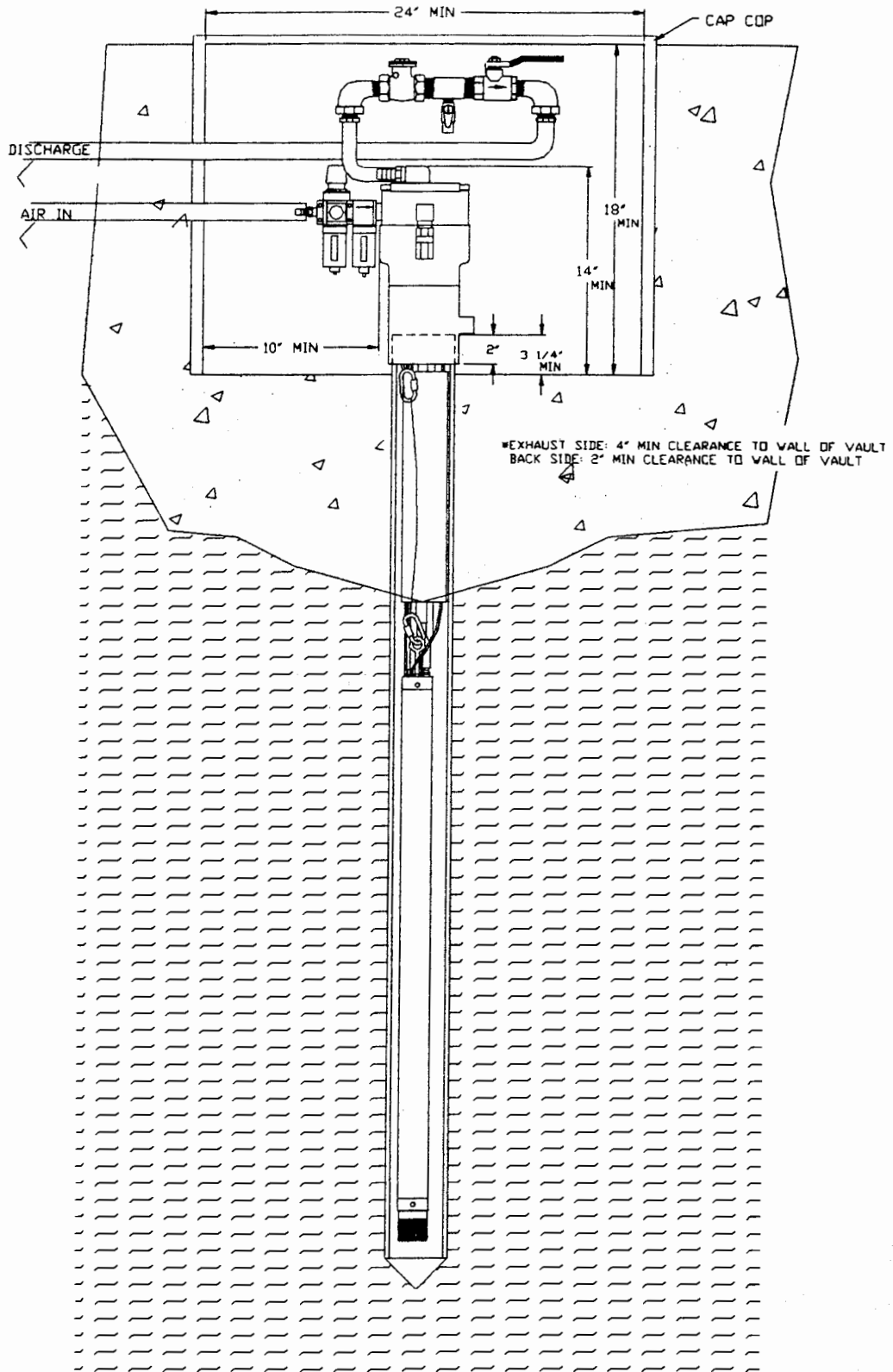

(LEV112)

Pump w/ SVE Manifold Installation and Pulse Counter Installation Set-up

Figure 8

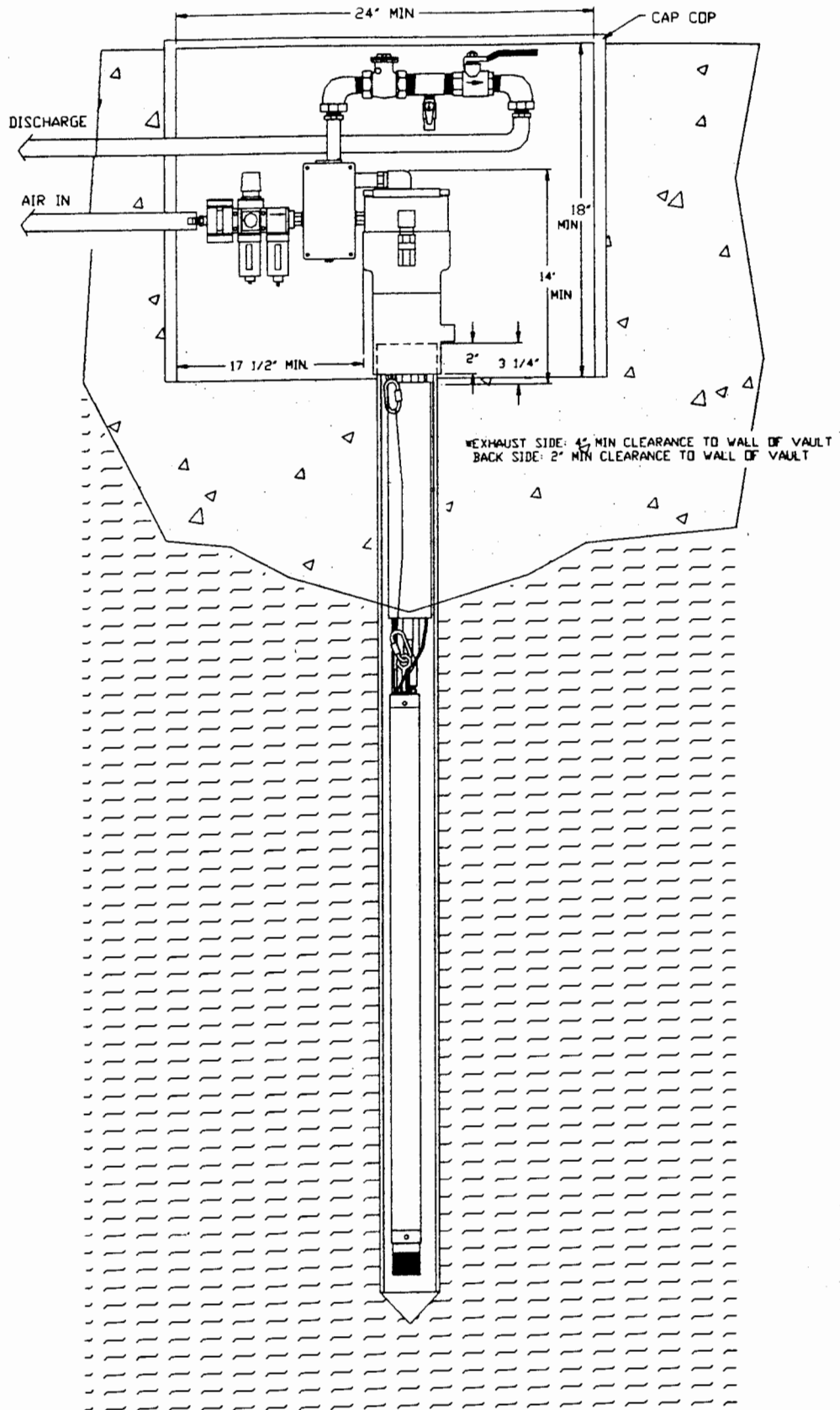

Well Clincher Parts Drawing

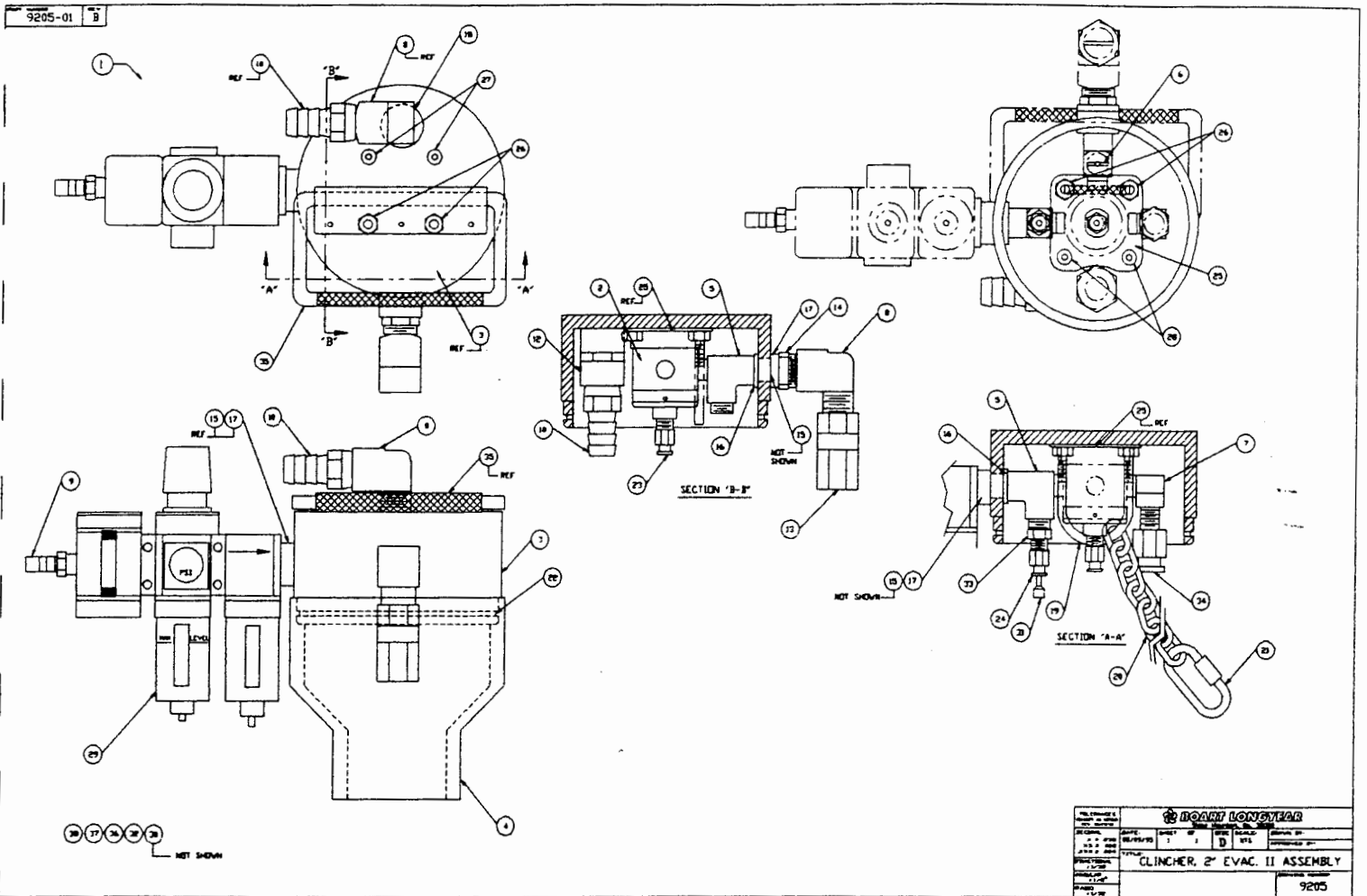

Well Clincher Parts List

ITEM	QTY	QTY	QTY	QTY	PART NUMBER	DESCRIPTION	SUPPLIER / MANUFACTURER
①	X				9205-01	CLINCHER, 2" EVAC II, ASSEMBLY	
②	1				2152-038	3 WAY VALVE	
③	1				9183-01	FLAT TOP, 4" PVC CAP MODIFIED	
④	1				9206-01	BELL REDUCER 4" X 2" SCH 80 -MODIFIED-	
⑤	2				2151-251	1/4" STREET TEE	
⑥	1				9188-01	1/4" SLOTTED HEAD PLUG MODIFIED	
⑦	1				2151-315	1/4" X 90° STREET ELBOW	
⑧	2				2151-351	1/2" 90° ST ELBOW	
⑨	1				2151-250	FITTING, 1/2" BARB X 1/4 MPT	
⑩	2				2151-171	HOSE BARB, 1/2 HOSE X 1/2 NPT	
⑪							
⑫	1				2151-204	COUPLING BRASS, 1/2" FNPT	
QUANTITY FOR PART NO.	9205-01						
PROJECT						TITLE CLINCHER, 2" EVAC. II ASSEMBLY	
REVISION							
DATE							
DATE							
SHEET 1 OF 4						DRAWING NO. 9205	

2" Well Clincher PartsList

ITEM	QTY	QTY	QTY	QTY	PART NUMBER	DESCRIPTION	SUPPLIER / MANUFACTURER
13	1				2151-239	CHECK VALVE, BRASS W/SEAL	
14	1				2151-197	BUSHING BRASS 1/4" FNPT X 1/2" MNPT	
15	2				2151-353	1/4 X 1.125 NIPPLE	
16	2				9185-16	WASHER, 9/16 ID X 1" OD X .125"	
17	2				9185-17	WASHER, 1/2" ID X 1" OD X .250	
18	1				9185-18	WASHER NYLON 7/8" ID X 1.125" OD	
19	1				9185-19	U-BOLT	
20	18"				9185-20	CHAIN, .158" DIA .890 INSIDE LENGTH .290 INSIDE WIDTH	
21	1				9185-21	QUICK LINK 3/16 W/ 1/4" LINK OPENING	
22	1				2404-156	O-RING #156	
23	1				2151-343	FITTING 1/8 TUBE X 1/8 MPT, BLACK	
24	1				2151-344	FITTING, 1/8 TUBE X 1/8 MPT GREEN	
QUANTITY FOR PART NO	9205-01						
PROJECT						TITLE CLINCHER, 2" EVAC. II ASSEMBLY	
REVISION							
DATE						DRAWING NO. 9205	
DATE 08/09/95							

2" Well Clincher Parts List

ITEM	QTY	QTY	QTY	QTY	PART NUMBER	DESCRIPTION	SUPPLIER / MANUFACTURER
25	1				9186-01	MOUNTING BASE MODIFIED	
26	4				-----	1/4 S.S. HEX NUTS	
27	2				-----	10-24 X 5/8 S.S. BUTTON HEAD SCREWS	
28	2				-----	10-24 S.S. NUTS	
29	1				300637	FILTER/REGULATOR PLUS COELESCING FILTER COMBINATION	
30	REF				300638	REPLACEMENT FILTER FOR 300637	
31	1				2151-355	PLUG, 1/8 TUBING	
32	REF				9185-32	SS CABLE 7 X 19 STRAND, 1/8 DIA.	
33	1				2151-360	1/4 X 1/8 REDUCER	
34	1				2151-345	1/4 MNPT X 1/2 TUBE, CONNECTOR	
35	1				9185-35	HANDLE, MODIFIED -DETAIL-	
36	REF				9185-36	COMPRESSION SLEEVE, 1/8" SS	
QUANTITY FOR PART NO.	9205-01						
PROJECT						TITLE CLINCHER, 2" EVAC. II ASSEMBLY SHEET 3 OF 4	
REVISION							
DATE							
DATE							
						DRAWING NO.	9205

2" Well Clincher Parts List

ITEM	QTY	QTY	QTY	QTY	PART NUMBER	DESCRIPTION	SUPPLIER / MANUFACTURER
37	REF				9185-37	1/8" GALV. WIRE ROPE CLIP	
38	3				2151-371	HOSE CLAMPS SIZE OD 1/4" - 5/8"	
39							
40							
41							
42							
43							
44							
45							
46							
47							
48							
QUANTITY FOR PART NO.	9205-01						
PROJECT						TITLE CLINCHER, 2" EVAC. II ASSEMBLY	
REVISION							
DATE							
DATE						SHEET 4 OF 4	DRAWING NO. 9205

2 In. Bottom Loading Pump Parts Drawing

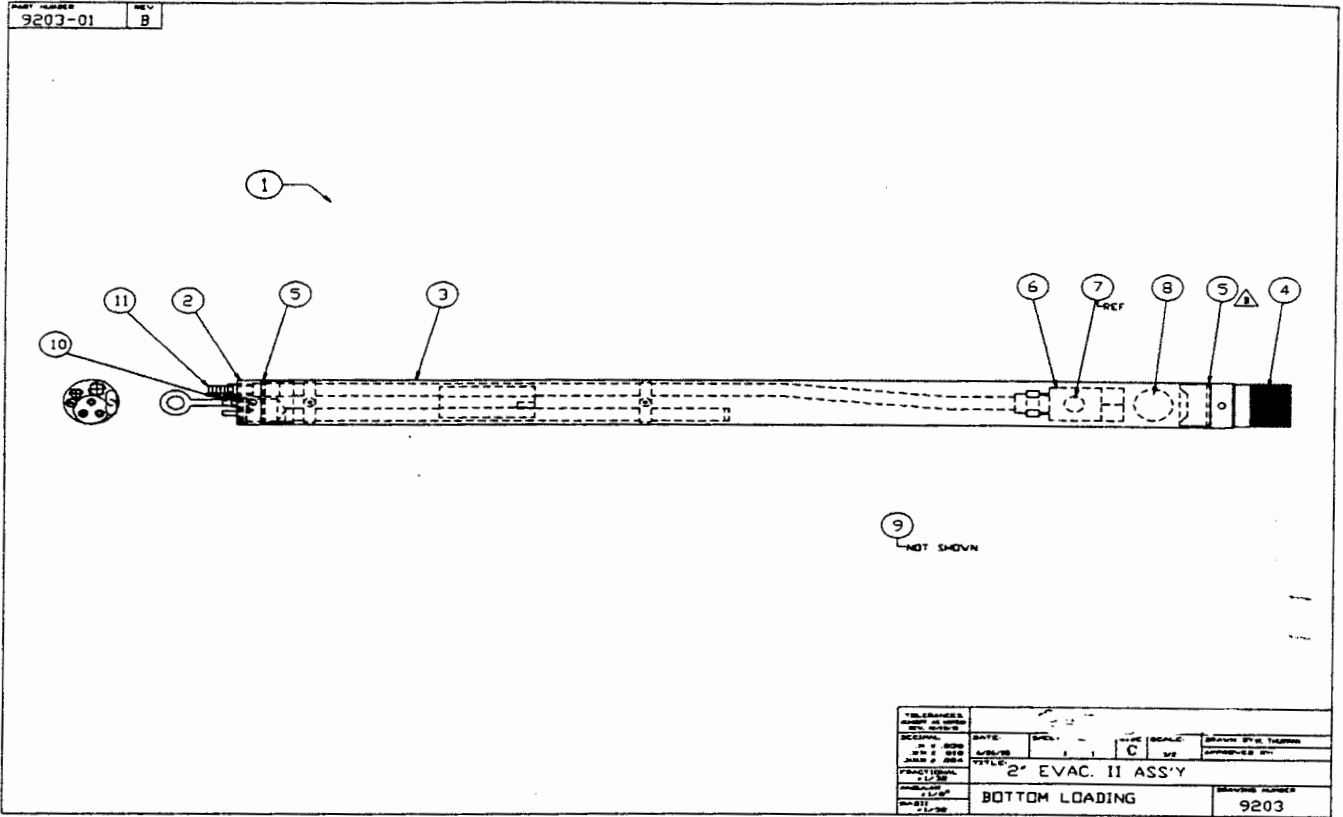

2 Inch Bottom Loading Pump Parts List

ITEM	QTY	QTY	QTY	QTY	PART NUMBER	DESCRIPTION	SUPPLIER / MANUFACTURER
1	X				9203-01	2" EVAC. II ASSY BOTTOM LOADING	
2	1				9202-01	HEAD ASSEMBLY, 2" EVAC. II	
3	1				9196-01	MIDBODY, 2" EVAC. II	
4	1				9200-01	BOTTOM ASS'Y, 2" EVAC. II	
5	2				2404-024	O'RING, #-024	
6	1				9065-04	CHECK VALVE, MODIFIED	
7	REF				9118-06	BALL, 5/8 DIA VITON BALL	
8	1				9203-08	1 1/4 TEFLON BALL	
9	2				9130-13	WRENCH, PIN STYLE (NOT SHOWN)	
10	1				2151-364	1/8 NPT X 3/8 BRASS HOSE BARB	
11	1				2151-250	1/4 NPT X 1/2 BRASS HOSE BARB	
12							
QUANTITY FOR PART NO.	9203-01						
PROJECT						TITLE	
TR-121						2" EVAC. II ASSY, BOTTOM LOADING	
REVISION						SHEET 1 OF 1	
DATE							
DATE							
						DRAWING NO	9203

2 Inch Top Loading Pump Parts Drawing

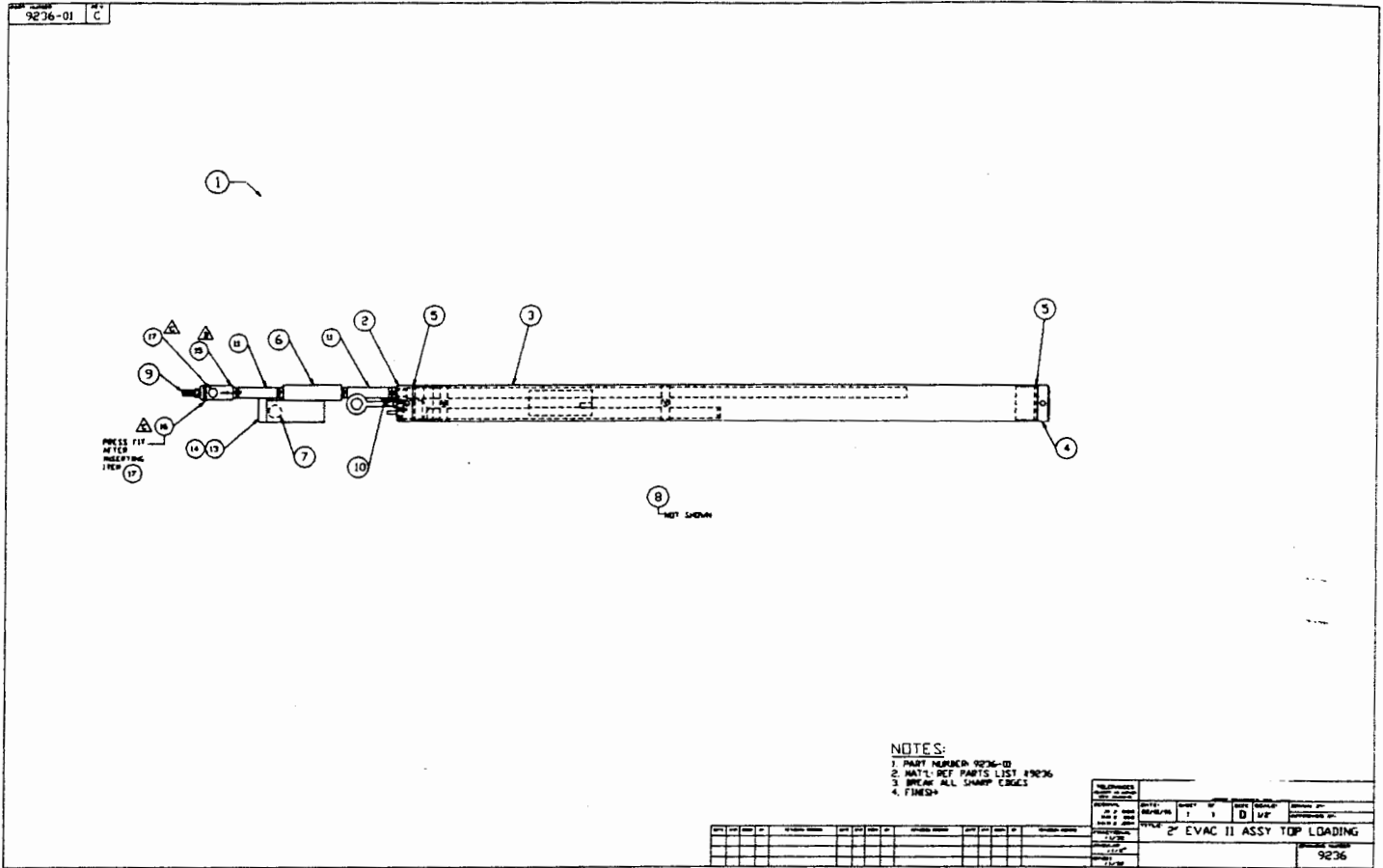

2 Inch Top Loading Pump Parts List

ITEM	QTY	QTY	QTY	QTY	PART NUMBER	DESCRIPTION	SUPPLIER / MANUFACTURER
①	X				9236-01	2" EVAC. ASSEMBLY (TOP LOADING)	
②	1				9202-16	HEAD ASSEMBLY 2" EVAC II (TOP LOADING)	
③	1				9196-01	MID BODY	
④	1				9233-01	BOTTOM PLUG	
⑤	2				2404-024	O RING (VITON) # 024	
⑥	1				9235-01	INTAKE VALVE BODY WELDMENT (TOP LOADING)	
⑦	1				300767	BALL 11/16 DIA NYLON GRADE 1	
⑧	2				9130-13	WRENCH, PIN STYLE	
⑨	1				2151-250	1/4 NPT X 1/2 BRASS HOSE BARB	
⑩	1				2151-364	1/8 NPT X 3/8 BRASS HOSE BARB	
⑪	2				9241-01	1/4 X 3" MODIFIED SS 304 NIPPLE	
⑫							
QUANTITY FOR PART NO.	9236-01						
PROJECT						TITLE 2" EVAC II ASSEMBLY TOP LOADING	
REVISION							
DATE							
DATE 02/01/96						SHEET 1 OF 2 DRAWING NO. 9236	

ITEM	QTY	QTY	QTY	QTY	PART NUMBER	DESCRIPTION	SUPPLIER / MANUFACTURER	
13	1				9234-01	SEAT, INTAKE VALVE		
14	1				300548	BRASS WASHER 1.131 OD X .956 ID X .030 TK		
15	1				300719	CHECK VALVE, MODIFIED		
16	1				300765	PIN 1/8 S.S. CHECK VALVE 2" EVAC II		
17	1				300766	BALL, 7/16 DIA 440 S.S.		
18								
19								
20								
21								
22								
23								
24								
QUANTITY FOR PART NO.		9236-01						
PROJECT						TITLE 2" EVAC II ASSEMBLY TOP LOADING		
REVISION								
DATE								
DATE						DRAWING NO.		
02/01/96						SHEET 2 OF 2 9236		

Warranty Statement

Durham Geo warrants that equipment shall be free from defects in material and workmanship for a period of **90 days** from the time the equipment is put into service. In any event, the warranty period will not exceed **6 months** from the date of shipment.

Durham Geo's liability shall be limited to replacement of components or equipment (at the manufacturer's discretion) that has been determined by the manufacturer to be faulty. No claims in excess of component replacement value will be recognized. Durham Geo will not be held liable for damages or lost business relating to a warranty claim.

Specifically excluded from this warranty are claims deemed by the manufacturer to have resulted from normal wear and tear, improper use, or abuse of the equipment.

For complete warranty disclosure, please call 1-800-837-0864 (outside GA) or 770-465-7557 (inside GA) or refer to the printed statement on the back of any Durham Geo original invoice.